

# RUNNING GEAR



Edited by Gurth



# Contents

<b>Hold-outs</b>	<b>6</b>	<b>VEHICLES</b>	<b>32</b>
Colt Take-Down	6	Chrysler-Nissan Python Turbo	32
Hämmerli Model 520	7	Eurocar 3000	32
North Industries Firing Knife	7	Fledermaus PKF40 Ausf. B	33
Star Model DWT	8	McDonnell Douglas C111	34
<b>Light Pistols</b>	<b>8</b>	<b>Hold-Out</b>	<b>35</b>
Ares AMP	8	Ceska Diplomat	35
Heckler & Koch P11	8	<b>Light Pistol</b>	<b>36</b>
Micro Uzi III	9	Seco Quickfire	36
Smith & Wesson Model 6739	9	<b>Heavy Pistols</b>	<b>36</b>
<b>Heavy Pistols</b>	<b>10</b>	Beretta 100S	36
Beretta Model 95S	10	Bond & Carrington MP-11	36
Beretta Model 110-T	10	Browning Defender 10	37
SuperEagle	11	Colt Penetrator	38
Ruger Warhawk	11	Fichetti Hurricane	38
Sig Sauer P300	11	Fichetti Military XI	38
Zastava Magnum Model 2054	12	Heckler & Koch OHWS	40
<b>Tasers</b>	<b>12</b>	Ingram Mk IV	40
Colt TP-6A	12	Ruger P-105	41
<b>Submachine Guns</b>	<b>13</b>	<b>Submachine Guns</b>	<b>41</b>
FN P55	13	Defiance AT-900	41
Ingram MAC-20	14	Sandler Model II	42
Steyr MP i 25	14	Walther S900	42
Uzi IV	14	<b>Sniper Rifle</b>	<b>42</b>
<b>Sniper Rifle</b>	<b>15</b>	Heckler & Koch PSG-65	42
RAI Model 1050	15	<b>Shotguns</b>	<b>43</b>
<b>Shotguns</b>	<b>16</b>	Ares Wippet	43
Holland & Holland .600 Nitro Express	16	Chandler Capture 100	43
Kimatsuhama Under-Barrel Shotguns	17	Ranger Arms Security 12	43
Sandler "Mad Max"	18	Remington 1628	43
<b>Assault Rifles</b>	<b>18</b>	Remington Rapid Assault 12	44
Heckler & Koch 70	18	<b>Multi-Weapon</b>	<b>44</b>
Honda AR-1	19	Mossberg M-712 Multi-Weapon System	44
SIG 88x-series	19	<b>Assault Rifles</b>	<b>44</b>
<b>Grenade launcher</b>	<b>20</b>	Kalishnikov AK-100	44
Rockwell AGL-113	20	Kalishnikov AK-101	45
<b>Heavy Weapons</b>	<b>20</b>	FN-ARGL	46
Ares MP Maser	20	Seco M-995	46
M400 Heavy Machine Gun	21	<b>Grenade Launcher</b>	<b>47</b>
Mistubishi Guardian™	22	Ares Suppressor	47
Whitney-Morgan Caseless Machine Gun	22	<b>Light Machine Gun</b>	<b>47</b>
<b>Melee Weapons</b>	<b>23</b>	IWS Mini-5	47
Mersch MX-23 Stunlance	23	<b>Heavy Weapon</b>	<b>48</b>
<b>Exotic</b>	<b>23</b>	IWS Assault 20	48
Sonic Stunner	23	<b>Ammunition</b>	<b>49</b>
<b>Accessories</b>	<b>24</b>	High Explosive Squash Head (HESH)	49
Gun Camera	24	Shotgun Mini-Grenade	49
Revolver Silencer	24	<b>ARMOR</b>	<b>50</b>
Smartscope	25	Heavy Leather (Jacket or Pants)	50
SumnerTech Gyro-Mount 1S	25	Kevlar T-Shirt/Vest	50
<b>AMMUNITION &amp; EXPLOSIVES</b>	<b>26</b>	Kevlar Armor Jacket	50
Anti-Armor Grenade	26	Helmet	51
Claymore	26	Flack Vest	51
CS Grenade	26	Doorgunner's Vest	51
Duplex Ammo	27	MetalGear™	51
Firepower™ Ammo	27	<b>COMMUNICATIONS</b>	<b>52</b>
Gas Grenade	27	Mastoid Commo	52
Glaser™ Ammo	28	Pocket Commo	52
Hollow Point Ammo	28	<b>VEHICLES</b>	<b>52</b>
Scatter Grenade	28	Bell Boeing V-22B Osprey	52
Shaped Charge	29	Bell F-152 Aerogyro	52
<b>GEAR</b>	<b>29</b>	Honda Metrocar	53
Armament Briefcase	29	McDonnell-Douglas AV-4	53
Fire-Resistant Coveralls	30	AV-6 Combat Assault Vehicle	53
Kelmar Police Armor	30	Toyo-Chrysler Omega	54
Sneak Suit	30	Toyota Avante	54
Superball	31	<b>WEAPONS</b>	<b>54</b>
Thermographic Camouflage Dye	31	<b>Melee Weapons</b>	<b>54</b>

Kendachi Monokatana®	54	Pocket Secretary	70
Kendachi Monoknife®	54	Telephone	70
<b>Projectile Weapons</b>	<b>54</b>	Optical Chip	70
EagleTech "Stryker" Crossbow	54	Explode	71
EagleTech "Tomcat" Compound Bow	55	<b>COMPOUNDS</b>	<b>72</b>
<b>Hold-Out Pistols</b>	<b>55</b>	<b>Depressants</b>	<b>72</b>
BudgetArms C-13	55	Alcohol	73
Dai Lung Cybermag 15	55	Barbiturates	73
Federated Arms X-22	55	Benzodiazepines	73
<b>Light Pistols</b>	<b>55</b>	Butaqualide	73
Dai Lung Streetmaster	55	Chloral Hydrate	73
Federated Arms X-9mm	56	Glutethimide	74
Militech Arms Avenger	56	Marijuana	74
<b>Heavy Pistols</b>	<b>56</b>	Methaqualone	74
Armalite 44	56	Nicotine	74
BudgetArms Auto 3	57	Paxium	74
Colt AMT Model 2000	57	Sonniene	75
SternMeyer Type 35	57	<b>Designer Drugs</b>	<b>75</b>
<b>Tasers</b>	<b>57</b>	Schwarzeneine	75
Miltech Electronics Taser	57	Shades	75
<b>Submachine Guns</b>	<b>58</b>	NuYou	75
Arasaka Minami 10	58	Musk	76
Federated Arms Tech Assault II	58	FoolKiller	76
H&K MP-2013	58	Diamond-Four	76
H&K MPK9	59	Genesios Three	76
H&K MPK-11	59	<b>Hallucinogens</b>	<b>77</b>
Ingram MAC-14	59	Ecstasy	77
Sternmeyer SMG 21	60	LSD	77
Uzi Miniauto 9	60	MDA, MDMA, and other Amphetamine variants	77
<b>Shotguns</b>	<b>60</b>	Mescaline	78
Arasaka Rapid Assault Shot 12	60	Phencyclidine	78
Sternmeyer Stakeout 10	60	Ribopropylmethionine	78
<b>Assault Rifles</b>	<b>61</b>	Zen	79
AKR-20 Medium Assault	61	<b>Narcotics</b>	<b>79</b>
FN-RAL Heavy Assault Rifle	61	Heroin	79
Kalashnikov A-80 Heavy Assault Rifle	62	Hydromorphone	79
Militech Ronin Light Assault	62	Meperidine	79
<b>Grenade Launcher</b>	<b>63</b>	Methadone	80
Grenade Launchers	63	Morphine	80
<b>Heavy Weapons</b>	<b>63</b>	Opium	80
Barrett-Arasaka Light 20mm	63	<b>Stimulants</b>	<b>80</b>
Scorpion 16 Missile Launcher	63	Amphetamines	80
Militech Rocket-Grenade Launcher	63	Brown Study	81
<b>SHAPED EXPLOSIVES</b>	<b>64</b>	Caffeine	81
<b>Detonators</b>	<b>64</b>	Cocaine	81
Radio Detonator	64	Endorphins	81
Timer Detonator	64	J	82
Laser Detonator	65	Methylphenidate	82
Pressure Detonator	65	Phenmetrazine	82
Pull Detonator	65	Spaz	82
Electric Detonator	65	Triphetamines	82
Sound Detonator	65	<b>FLORA</b>	<b>83</b>
Light Detonator	66	Aloe (Awakened)	83
<b>Shaped Explosives</b>	<b>66</b>	Autumn Crocus	83
Game notes	66	Balsam of Peru (Awakened)	84
Arrow	66	Barvine	84
Book	67	Belladonna	84
Bottle	67	Black Nightshade	85
Brick	67	Name: Calabar Bean	85
Bullet	68	Catnip (Awakened)	85
Button	68	Chat	85
Can	68	Demonseed	85
Compact Disk	68	Foxglove	86
Credstick	68	Godflesh	86
Datajack Plug	69	Healing Snakeroot	86
Doormat	69	Hemlock	87
Flower	69	Herb Mercury (Awakened)	87
Keycard	70	Hound's-tongue (Awakened)	87
Lightbulb	70	Jamaica Quassia	87
Pen	70	Kava	88
		Mandrake (Awakened)	88

Mirror Basil	88
Moneywort (Awakened)	89
Opium Poppy	89
Pareira	89
Peyote	89
Rauwolfia	90
Sea Onion	91
Sinicuichi	91
Smooth Strophanthus	91
Fly agaris (Awakened)	91
St. Michael	92
Strychnine Tree	92
Tess' Bloom	93
Torus Buckthorne	93
Vambane	93
Underdog	93
<b>FAUNA</b>	<b>94</b>
Cyrano	94
Gin toad	94
Marine toad	94
<b>RADTECH INC. EQUIPMENT CATALOG</b>	<b>96</b>
<b>Skate skill</b>	<b>96</b>
Rechargeable Battery Pack	96
RadTech Patented SmartWheel and Surface Imaging	97
Sonar/SmartLogic Electronics	97
Sonic-II SkateBoard	97
Spider-IX SkateBoot	97
<b>RadTech Patented MagnaPoon</b>	<b>98</b>
StreetMaster PoonGun	98
Highway-Hawk Mark-II PoonGlove	98

## Writing

Introduction: Gurth  
 New Stuff: Gurth  
 SWO Guns: the members of S.W.O.  
 CP2020: the Cyberpunk 2020 designers  
 Shaped Explosives: Gurth  
 Drugs: Seth Narins, Wordman and Brijesh  
 Gill  
 RadTech: Storm Widow

## Editing and Lay-Out

Gurth

## Illustrations

Gurth (New Stuff)  
 the members of SWO (SWO Guns)  
 the CP2020 ilustrators (CP2020)  
 some anonymous others as well  
 (BTW, the Plastic Warriors logo was stolen from Tech  
 Readout 3026.)

*Gurth@dds.nl* or *Gurth@xs4all.nl* (nb: Gurth is no longer to be reached at *jweste%smtp@htshlo.hzeeland.nl* [like anyone cares...]). Geek Code v2.1: GS/AT/! -d+ H s:- !g P?(3) !au !a>? w+(+++)\*v\*(---) C+(++) U P? !L !3 E? N++ K- W+ -po+(po) Y+ t(+)\*5 !j R+(++)>++++\$ tv+(++) b+@ D+(++) B? e+ u+@ h! f-- (?) !r(--)(\*) n---->!n y?

This file may be freely distributed in electronic or hardcopy format, but only at no cost to the recipient other than costs involved in the distribution (photocopier costs, buying diskettes, and so on), and as long as it is not modified in any way. You may modify it for your own use, but you may not distribute modified versions.

**Shadowrun** is a registered trademark of FASA Corporation. It's been said before and I'll say it as well: they actually make money off of the game.  
**Cyberpunk** is R. Talsorian's trademark for "it's adventure game of the dark future." (note that they mis-spelled "its" :)

This compilation © 1994 Gurth. Individual articles  
 copyright © by their authors.  
 Printed in (fill in your country here)

# RUNNING GEAR

## Spring 2055 Update

Hi there, hi there, hi there! We spent the last couple of months digging in the Matrix to bring you this update on the latest toys for runners (and the corps) to play with. The results of our venturing into dangerous, uncharted datastores have been neatly categorized and sorted out for your enjoyment, and are presented on the next pages of this file.

The file is divided into the following parts:

- *Update*: what you're looking at now.
- *New Stuff*: all kinds of new equipment, never published before.
- *SWO Guns*: the first part of the SWO Guns file.
- *CP2020*: guns and gear from R. Talsorian's Cyberpunk 2020.
- *Explosives*: explosives in all shapes and sizes.
- *Drugs*: expand the mind (or waste it).
- *RadTech Inc. Equipment Catalog*: alternative forms of transport.

These bits were taken from all kinds of sources, not all of them will probably agree, but that's too bad.

As a note, **SRII** refers to Shadowrun Second Edition, and **FOF** refers to Fields of Fire.

For your enjoyment,

the Plastic Warriors



## Weapons

### Hold-outs

#### Colt Take-Down

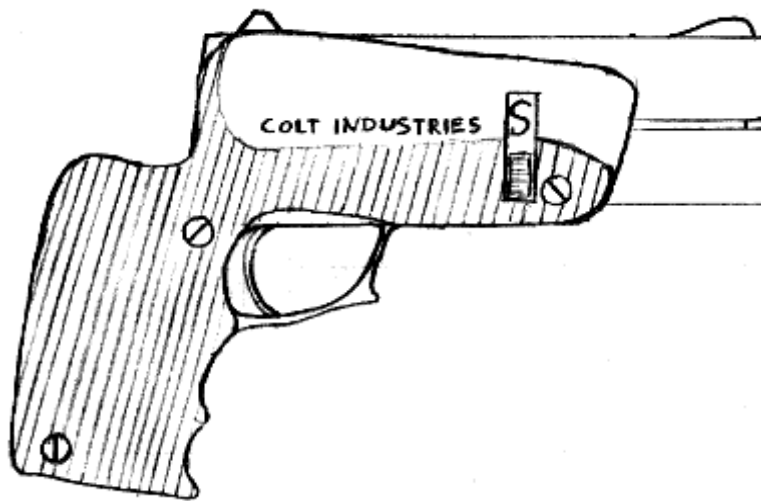

A hold-out pistol with a difference: where most hold-outs pack no more punch than an air gun, this one fires heavy pistol rounds from its over-under barrels! Both barrels can be fired virtually simultaneously, for devastating effects!

Type	Conceal	Ammo	Mode	Damage	Weight	Availability	Cost	Street Index
Hold-Out	8	2 (b)	SA	7M	.5	4/12hrs	150¥	.8

One barrel can be fired in one Simple Action; the weapon is very light, so it uses heavy weapon recoil rules, while its very short barrels give it a +1 Target Number modifier at Medium range, +2 at Long range, and +4 at Extreme range. The pistol, though technically a hold-out, fires heavy pistol rounds.

>>>>[Finally a hold-out that makes sense. The way I see it, you pack a hold-out as the last defense if something nasty is going on; with those Streetline Specials, you can't even kill a fly because its armor is too tough...this one is great!]<<<<<  
 —Garvey (15:32:07/05-05-55)

>>>>[The way you hold this thing is a bit strange at first, but you get used to it pretty soon. You put your middle finger of the trigger, your index finger on the right (or left, if you're left handed) side of the receiver, resting on the safety catch, and your thumb goes behind the top barrel. It feels strange, but in this way you have the barrels in front of your hand, and that reduces recoil significantly. The gun's only got the mass of a hold-out, after all.]<<<<<  
 —Aunt Annie (02:38:55/05-09-55)

### Hämmerli Model 520

A high-tech sporting weapon for the marks-person, the Model 520 is extremely accurate. It is made almost entirely from carbon fibre and impact plastics, and is customized for the purchaser as standard. The extremely balanced construction makes for stable firing, while the weapon can still accept barrel- and top-mounted accessories, even though it is a hold-out!

Type	Conceal	Ammo
Hold-Out	4	6(c)
Mode	Damage	Weight
SA	4L	1.25
Availability	Cost	
8/4 days	1,000¥	
Street Index		
1		

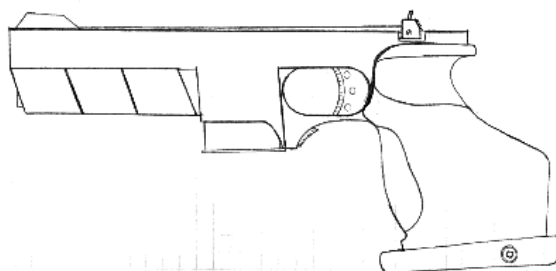

At all ranges beyond short, apply a -1 modifier to the Target Number due to the accuracy of the weapon. The stable construction provides one point of recoil compensation, but if any accessories are fitted, this point is lost because the delicate balance is lost.

>>>>[The standard customization is, of course, only if you buy the weapon from an official retail outlet. Most fixers don't provide this service.]<<<<<  
 —Hairy Harry (13:04:05/05-07-55)



### North Industries Firing Knife

An unusual weapon, combining a knife and a hold-out pistol into one. The weapon looks like a medium-sized knife, but the grip has two barrels inside (one on either side of the blade), and a revolver-type magazine for five rounds. To fire, simply point the knife at the target and pull the trigger!

Pistol:

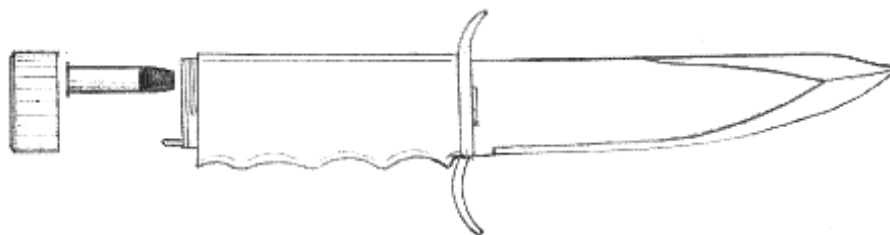

Type	Conceal	Ammo	Mode	Damage	Weight	Availability	Cost	Street Index
Hold-Out	6	5 (cy)	SA	4L	.5	5/12hrs	250¥	1
Knife:								
Reach	Damage							
0	(str+1)L							

The two barrels allow a higher rate of fire than normally possible with a revolver mechanism, increasing the ROF to SA.

>>>>[This isn't an original design. In the 1980s, or maybe even earlier, the Chinese already made a weapon much like this one, and it seems like it was a copy of a Czech design even then.]<<<<<  
 —Mikey-Boy (20:17:08/05-02-55)

>>>>[Whatever. Just stab someone and pull the trigger.]<<<<<  
 —Howl (06:00:52/05-04-55)

>>>>[Can't it go off accidentally?]<<<<<

—Hairy Harry (13:41:57/05-07-55)

>>>>[Not if you leave the safety on. The trigger (which also functions as the hand guard) is locked when the safety is on, so you can't accidentally fire it if, say, the trigger catches behind your clothes.]<<<<<

—Mikey-Boy (18:05:36/05-10-55)

### Star Model DWT

Imported into the UCAS and CAS by Ares Arms, this small pistol from Spain is one of the best and most reliable in its class.

Type	Conceal	Ammo	Mode	Damage	Weight	Availability	Cost	Street Index
Hold-Out	7	6 (c)	SA	5L	.5	3/18hrs	300¥	.8

>>>>[And that says something about the rest...]<<<<<

—Garvey (15:34:31/05-05-55)

### Light Pistols

#### Ares AMP

Ares' new Assault Machine Pistol provides high firepower in a small package! It can be fired from one hand if needed, though it is also equipped with a folding stock to allow firing from the shoulder. The large clip capacity allows sustained fire, while the gas vent system (a Lyco Systems rating 2 Improved) makes it easily controllable.

Type	Conceal	Ammo	Mode	Damage	Weight	Availability	Cost	Street Index
Light	6	40 (c)	SA/BF/FA	6L	2.75	8/36hrs	1,000¥	2

>>>>[Don't believe the hype. This thing looks like a new design, but when you look inside you see the old Crusader MP mechanism with a full-auto mode bolted on. They only altered the exterior styling to make it appear a new weapon.]<<<<<

—Chat (06:31:02/05-05-55)

>>>>[You don't have to buy this thing to rock 'n' roll if you own a Crusader already. What you do is take your Crusader to your favorite armorer, and get him to dig up a few AMP spare parts to convert your Crusader to full-auto mode. Shouldn't cost you more than maybe a hundred yens.]<<<<<

—Wanker (04:33:06/05-09-55)

#### Heckler & Koch P11

An all-new light and easily concealable pistol from the well-known H&K, the P11 is designed for those who need a firearm but do not want to advertise its presence. The P11 does not come with accessories, but can be fitted with all normal accessories, except stock-mounted ones.

Type	Conceal	Ammo	Mode	Damage	Weight	Availability	Cost	Street Index
Light	8	8 (c)	SA	6L	1	5/36hrs	600¥	1.25

>>>>[This guide fails to mention that the weapon described above is called "P11M8." The P11M13 has a 13-round clip in almost exactly the same weapon, though the clips are not interchangeable. The M13 costs 650¥ according to the spring '55 H&K catalog.]<<<<<

—Latex Louis (22:51:39/05-09-55)



## Micro Uzi III

A very small version of the familiar Uzi III, this weapon is much more like a light pistol than an SMG. It features burst-fire capability, like the weapon it evolved

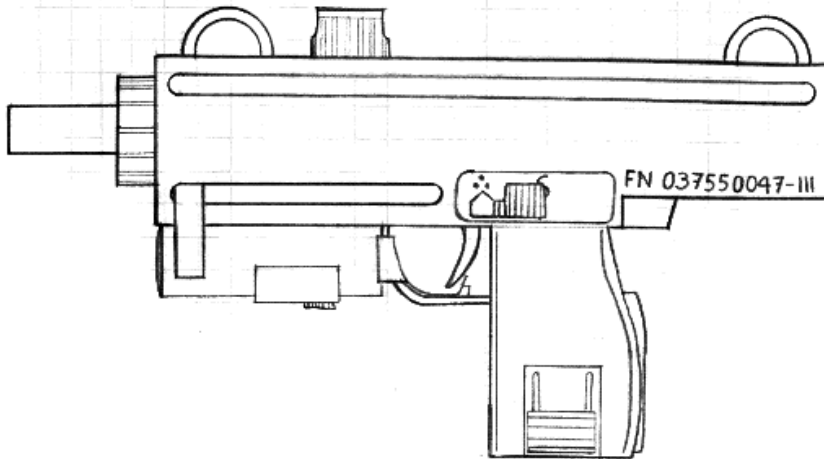

from, and also included in this stockless design is an under-barrel-mounted laser sight.

Type	Conceal	Ammo	Mode	Damage	Weight	Availability	Cost	Street Index
Light	6	16 (c)	BF	6L	1.5	6/36hrs	750¥	1

>>>>[This thing's value seems pretty dubious to me. Why not just pack a full-size Uzi III, or even better, the new Uzi IV?]<<<<<  
 —Carina (05:19:50/05-03-55)

>>>>[Sometimes you need concealability and firepower. This thing has both, I feel.]<<<<<  
 —Sassy (03:12:00/05-07-55)

>>>>[For the same weight and size (and less nuyen), you can also pack a heavy pistol.]<<<<<  
 —Coyote (14:41:17/05-11-55)



## Smith & Wesson Model 6739

A self-defense revolver, the 6739 is highly concealable, with its smooth design making it easy to quick-draw. The five-shot capacity gives ample firepower for such a small weapon!

Type	Conceal	Ammo	Mode	Damage	Weight	Availability	Cost	Street Index
Light	8	5 (cy)	SS	6L	.75	3/36hrs	250¥	.9

>>>>[Again, dubious value. It will scare street thugs, but any runner (or corp sec trooper) will shoot you first and laugh at your corpse when she's finished.]<<<<<  
 —Carina (05:21:47/05-03-55)

>>>>[Read the description: it is presented as being a "self-defense revolver," which means that it's supposed to scare thugs away, but not to shoot it at guys in heavy body armor. I can testify that a weapon of this class saved me from having my throat cut by some punks who weren't as tough as they looked.]<<<<<  
 —Terry Taxicab (13:02:39/05-16-55)

## Heavy Pistols

### Beretta Model 95S

A brand-new heavy pistol, the 95S comes equipped with an internal smartlink (level II) and a barrel-mounted gas vent system as standard. Its all-plastic and ceramics construction makes it easily concealable, plus there is also a model equipped with a three-round burst-capability, making it extremely deadly

Model 95S:

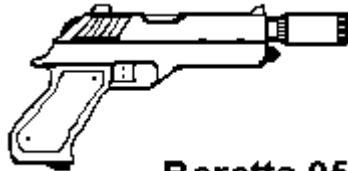

**Beretta 95S**

Type	Conceal	Ammo	Mode	Damage	Weight	Availability	Cost	Street Index
Heavy	5	15 (c)	SA	9M	2.5	3/24hrs	500¥	1
<b>Model 95S-B:</b>								
Type	Conceal	Ammo	Mode	Damage	Weight	Availability	Cost	Street Index
Heavy	5	15 (c)	SA/BF	9M	2.5	6/72hrs	750¥	1.75

When firing bursts, use heavy weapon recoil rules. The gas vent is rating 2 Improved.

(note: SWO gave a picture of this weapon (included here), but no description or game stats in their SWOGUNS1.TXT file, so I made up the above stats for the weapon in the drawing.)

>>>>[I got myself the -B model, but it's not as good as they make it out to be. The smartlink II is obviously some unlicensed copy made by retarded ghouls, 'cause half of the time it was fragging up the info it was feeding me: I had 2163 rounds left in my gun at one time, and at another I had centered the crosshairs on this chick's head and the gun was pointing at her boyfriend two meters to her left!]<<<<<  
 —Rellik (13:51:51/05-04-55)

>>>>[Echo that, the smartlink II in this weapon is of very dubious quality. It all goes well as long as you're using it with a level I smartlink, but as soon as you couple it with level II goggles or cyberware, it messes up everything. My guess is that they tried to update an original level I system to level II without doing their homework.]<<<<<  
 —Sister Sledgehammer (17:42:29/05-08-55)



### Beretta Model 110-T

A large and powerful pistol, the 110-T is the big brother of the Model 101-T. It comes with a top-mounted laser sight as standard.



**BERETTA  
MODEL 110-T**

Type	Conceal	Ammo	Mode	Damage	Weight
Heavy	5	16 (c)	SA	9M	2
Availability	Cost	Street Index			
3/24hrs	400¥	1			

(note: there is a picture of this weapon in the SR1 rulebook (page 121), but no game stats are given for it. This is my representation of the weapon in the drawing.)

>>>>[I'd rate this pistol above the Ares Predator.]<<<<<  
 —Freddy (15:21:15/05-15-55)

## SuperEagle

An Israeli design, the SuperEagle is a very powerful combat pistol for long-range engagements. Coming with an internal smartlink system, the SuperEagle provides tremendous long-range firepower!

Type	Conceal	Ammo	Mode	Damage	Weight	Availability	Cost	Street Index
Heavy	4	7 (c)	SA	11M	2.75	6/48hrs	600¥	1.5

Though technocally a heavy pistol, this wepaon uses shotgun ranges.

>>>>[Now this is a weapon that deserves the name.]<<<<<  
 —Coyote (14:43:55/05-11-55)

## Ruger Warhawk

A smaller, lighter, version of the well-known Super Warhawk, the Warhawk is still a powerful pistol by any standards. Like its larger relative, it accepts all accessories except silencers. Available in high-chromed and matt-black finish.



Type	Conceal	Ammo	Mode	Damage	Weight	Availability	Cost	Street Index
Heavy	5	6 (cy)	SS	9M	2	3/24hrs	250¥	1

>>>>[Got myself one of these to replace my worn-out Super Warhawk. Worst purchase I ever made in my life...after three days, the firing pin broke. Then after nine days, the chamber jammed and wouldn't turn until I'd fully stripped the weapon and cleaned it thoroughly. And as an extra bonus, it shoots high and to the left, even with the sights fully adjusted to compansate. My advice: get a good gun instead of this one.]<<<<<  
 —Pet Lamb (14:02:52/05-08-55)

>>>>[Hate to contradict you, Lamb, but everything I've heard and read about the Warhawk praises it to heaven and back. Are you sure you didn't have a weapon that the factory's quality control rejected? Some of those *do* get out on the streets sometimes, you know.]<<<<<  
 —Hitter (20:31:34/05-10-55)

## Sig Sauer P300

From Germany, an excellent heavy pistol for the professionals. It is in common use among special operations merc units, who favor it because of its integral silencer (barrel mount) and laser sight (top). Its matt-black, stainless steel finish makes the weapon reflect little light, and because it fires caseless ammunition, its mechanism is simpler than that of comparable weapons, making it more reliable than most of its competition.

Type	Conceal	Ammo	Mode	Damage	Weight	Availability	Cost	Street Index
Heavy	4	18 (c)	SA	9M	3.25	8/48hrs	800¥	2

>>>>[Nice weapon, but look at the price! 800 bucks for an overweight pistol!]<<<<<  
 —Bushwacker (18:17:56/05-07-55)

>>>>[The weapon is very respected among mercs, and I feel it has the abilities to become common on the street as well. The price is so high because of the high standard of manufacture, and the weight is because of the accessories. The clip capacity is one of the largest of any heavy pistol on the market today.]<<<<<  
 —Coyote (15:02:13/05-11-55)



## Zastava Magnum Model 2054

A product of the Serbian Republic, the Magnum M2054 is a powerful revolver, though it only has a short barrel. The weapon is of light construction, and is unusual in holding seven rounds instead of the more usual six. It accepts most accessories except silencers.

Type	Conceal	Ammo	Mode	Damage	Weight	Availability	Cost	Street Index
Heavy	5	7 (cy)	SS	9M	1.75	4/36hrs	350¥	.9

The short barrel gives this heavy pistol only light pistol ranges.

>>>>[The light construction gives it a punishing recoil.]<<<<<

—Sister Sledgehammer (14:03:53/11-07-55)

>>>>[Women aren't build to fire guns. They don't have the strength.]<<<<<

—Chester Fields (09:52:18/05-10-55)

>>>>[Chester my dear, you'd better haul your ass over to Bishop's tonight.]<<<<<

—Sister Sledgehammer (15:03:48/05-10-55)

>>>>[Erm, I think an apology is in place here. Sorry, it won't happen again. Next time, I'll think before I type...]<<<<<

—Chester Fields (12:52:23/05-11-55)

>>>>[Further down the file is a silencer for revolvers.]<<<<<

—Jack-All (06:42:59/05-15-55)



## Tasers

### Colt TP-6A

Colt's entry into the taser market dominated by Defiance and Yamaha up until now. The TP-6A was designed for security and law enforcement use, and fires small darts, of which it holds six in the hand grip. One slight disadvantage is that it must be cocked by hand before each shot, but according to Colt this feature has been incorporated to prevent accidental firings.

Type	Conceal	Ammo	Mode	Damage	Weight	Availability	Cost	Street Index
Taser	7	6 (m)	SS	8S	.75	6/24hrs	550¥	1

>>>>[Oh, Jesus. Another taser. Just what we were all waiting for. Get real. Get a gun.]<<<<<

—Rydergirl (03:06:16/05-10-55)

>>>>[A taser is more effective than a heavy pistol, to be honest. The high voltage disables your enemy quicker than a slug does, and, as someone pointed out somewhere, if the corp sec guys know you're not out to kill them, they might just be a little easier on you.]<<<<<

—Believer (05:31:41/05-10-55)

>>>>[Yeah, sure. Instead of killing you, they knock you unconcious so you can be interrogated in some dirty chamber by other corpers who give frag-all about human rights, after which you'll be shot in the back of the skull and dumped in a back alley.]<<<<<

—Kill Roy (13:52:39/05-13-55)

>>>>[You have to admit that a well-placed taser shot disables someone faster than a well-placed pistol shot. Shotguns and machine guns are a different matter entirely.]<<<<<

—4777 (23:42:36/05-15-55)

## Submachine Guns

### FN P55

The most recent update of a weapon series that has been in production for over 60 years, this weapon manages to remain up-to-date, and even ahead of some of its opposition despite the age of the original design! Though firing common submachine gun rounds, this slick design manages to squeeze assault rifle performance out of them! Incorporated into the front of the gun is a rating 2 telescopic sight, and a smartlinked version (which has a smartlink system in place of the 'scope) is also available, for only a 250¥ increase in price. Either version has a built-in gas vent system to reduce muzzle climb.

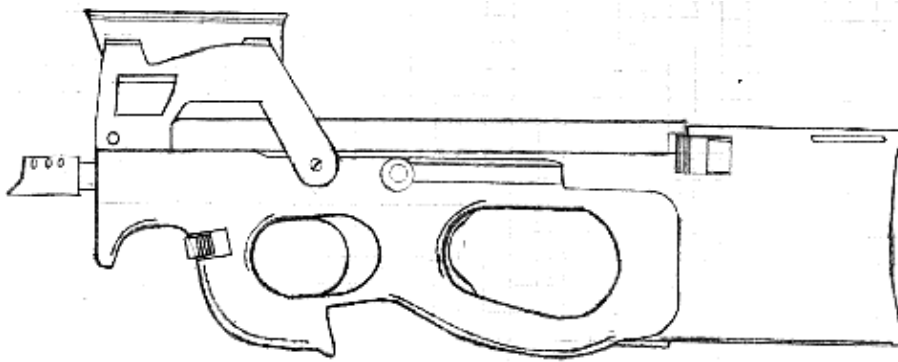

Telescope sight version:

Type	Conceal	Ammo	Mode	Damage	Weight	Availability	Cost	Street Index
SMG	5	50 (c)	SA/BF/FA	8M	3.5	8/4 days	650¥	2.5

**Smartlinked version:**

Type	Conceal	Ammo	Mode	Damage	Weight	Availability	Cost	Street Index
SMG	5	50 (c)	SA/BF/FA	8M	3.75	9/4 days	900¥	2.75

The telescopic sight is rating 2, while the gas vent is rating 2 Improved.

>>>>[I wouldn't trust my life on a weapon whose basic design is over 60 years old, at least not unless I really had to.]<<<<<  
 —Rellik (14:05:13/05-04-55)

>>>>[Believe me, loads of your colleagues do it all the time: what do you think the "97" in AK-97 stands for? And the original of that weapon dates back to 1947!! Given the choice, I'd go for the P55 over the AK anytime.]<<<<<  
 —Coyote (15:41:22/05-11-55)



### Ingram MAC-20

Ingram returns to its roots with the MAC-20! A very reliable no-frills SMG, the MAC-20 comes with an integral sound suppressor and a folding stock, and has the novel feature of an interchangeable barrel. By changing barrels (which takes about one minute), the weapon can fire either SMG or Heavy Pistol ammunition, though the weapon uses different clips in each configuration. For HP ammo, there is a 20-round clip, while the SMG ammo can be fired from either a 16-round or a 32-round clip. The MAC-20 cannot accept under-barrel or stock-mounted accessories.

	Type	Conceal	Ammo	Mode	Damage	Weight
SMG ammo	SMG	5	16 or 32 (c)	SA/FA	7M	3.5
HP ammo	SMG	5	20 (c)	SA/FA	9M	3.75
<b>Availability</b>	<b>Cost*</b>	<b>Street Index</b>				
6/48hrs	700¥	1.5				

\* = including barrels for HP and SMG ammo

The 16-round clip adds +1 to concealability and lowers overall weight by .25 kg.

### Steyr MP i 25

Austrian design and quality, the MP i 25 is everything you'll ever need in an SMG: compact, rugged, a folding stock, large clip capacity, integral gas vent system, and an internally-mounted laser sight. A definite winner.

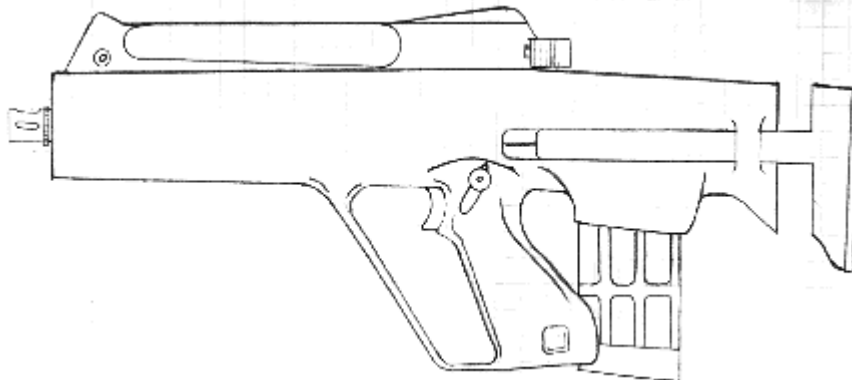

Type	Conceal	Ammo	Mode	Damage	Weight	Availability	Cost	Street Index
SMG	4	35 (c)	SA/BF/FA	6M	3.75	5/60hrs	725¥	2

The gas vent is rating 1, and the laser sight is mounted internally, so both the top- and under-barrel mounts are still free for other accessories.

### Uzi IV

Fabrique National's long-awaited upgrade of the Uzi III, this weapon is capable of all fire modes, has a larger clip capacity, and can still use all Uzi III clips. It comes in two models: one with a top-mounted laser sight, and one with an internal smartlink. Both weapons feature a gas vent on the barrel, but cannot mount any under-barrel accessories. The folding stock gives good concealability.

**Laser Sight model:**

Type	Conceal	Ammo	Mode	Damage	Weight	Availability	Cost	Street Index
SMG	4	30 (c)	SA/BF/FA	6M	3	6/60hrs	1,000¥	1

**Smartlinked model:**

Type	Conceal	Ammo	Mode	Damage	Weight	Availability	Cost	Street Index
SMG	5	30 (c)	SA/BF/FA	6M	3.25	8/60hrs	1,200¥	1.25

The gas vent is rating 2.



>>>>[I tested this weapon for a company that wants to import it into the CAS, and I can say that the design is of the same standard as the Uzi III. The gun fires like a dream, the gas vent makes it very controllable (unless you go for the rock 'n' roll mode), and FN have finally given the weapon other modes than just burst fire. I'd give it 8 out of 10.]<<<<<  
 —Ma Donna (23:05:36/05-13-55)



## Sniper Rifle

### RAI Model 1050

A new sniping rifle for long-range fire-power, this weapon's barrel is one large silencer, while a tele-scopic sight with low-light capability is standard (top mount), as is a high-power laser sight (under-barrel), effective out to 1500 meters at night, and 150 meters during the day. Also fitted are shock pads on the weapon's stock. When ordering a brand-new weapon straight from the factory, it is customized for the user at only a 4000¥ increase in cost. Because the entire barrel is a silencer, the weapon can still accept barrel-mounted accessories.



Type	Conceal	Ammo	Mode	Damage	Weight	Availability	Cost	Street Index
Sniper	—	5 (c)	SA	15S	5.25	14/10 days	6,000¥	4

The telescopic sight is rating 3.

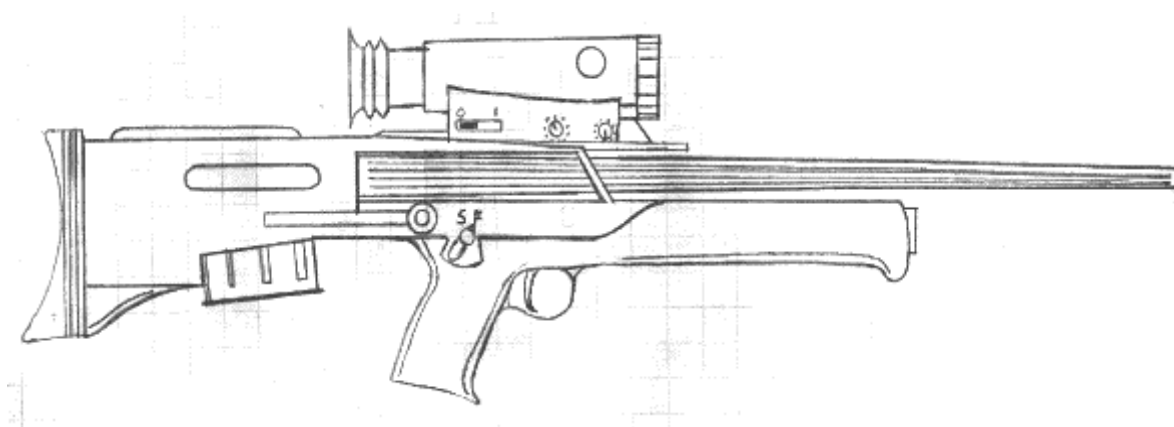

>>>>[Perfect for covert ops.]<<<<<  
 —Coyote (13:02:50/05-11-55)

## Shotguns

### Holland & Holland .600 Nitro Express

A fine shotgun from the United Kingdom, the .600NE is made completely by hand, in a tradition that goes back for over a century. These weapons are only made to order, to exact customer specifications, and come customized for the intended user as standard (though a non-customized weapon can also be bought at a 25% reduction in cost). Each weapon is unique, what more needs to be said?

The .600NE can be fitted with any desired accessories during manufacturing, but regrettably it is virtually impossible to fit accessories after manufacture.

Type	Conceal	Ammo	Mode	Damage	Weight
Shotgun	—	2 (break)	SA	12S	4.5
<b>Availability</b>	<b>Cost</b>	<b>Street Index</b>			
call H&H	10,000¥	—			

One barrel can be fired per Simple Action. Both barrels have a fixed choke, but the customer decides on the choke before manufacture. The .600NE is a shotgun, but uses its own special ammunition, which is available only in Buckshot (Flechette) and Regular versions, at double base price, +2 Availability, and double Street Index.

>>>>[Very nice, but what do runners like us have to do with a shotgun like this? This thing is totally unsuitable for shadowrunning, I mean, only two shots? And it doesn't fire standard shotgun ammo? And at that outrageous price?! No thanks.]<<<<<

—Bushwacker (18:32:00/05-07-55)

>>>>[You're missing the whole point of this weapon. It's not for runners or even combat use; it's for hunters who have enough nuyen to spend to buy a custom-built, hand-made weapon. H&H have been making guns like this one since time began, and their weapons are lightyears above the self-loading, mass-produced combat shotguns we runners tend to favor. This is a weapon for Johnsons who go duck hunting in their spare time.]<<<<<

—Freddy (15:30:49/05-15-55)

>>>>[Give me a self-loading, mass-produced combat shotgun anytime.]<<<<<

—Rellik (05:02:14/05-16-55)

>>>>[Me too, but that's not the point I'm trying to make. Oh, never mind...]<<<<<

—Freddy (13:32:58/05-16-55)



## Kimatsuhama Under-Barrel Shotguns

Short-barreled shotguns from Japan, providing impressive and immediate firepower without the need to ready another weapon before you can fire! These weapons mount on the under-barrel position of any weapon, and are provided with thumb-press electric triggers. Their design makes them very difficult to fire when not attached to another weapon.

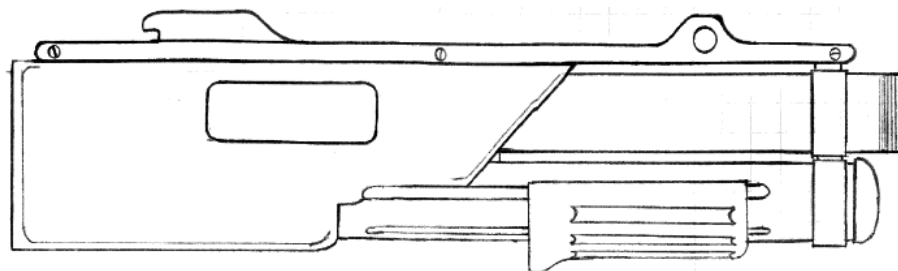

The series consists of the UBS-5, UBS-6, and UBS-7. The UBS-5 has a 4-shot internal magazine and uses pump-action, while the -6 increases the magazine capacity to 6 rounds and switches to semi-automatic operation. The UBS-7 is similar to the UBS-5, but has two barrels side-by-side, each with its own 4-round magazine! Both barrels can be fired simultaneously by pressing both triggers at once, for an even more dramatic effect!

### UBS-5:

Type	Conceal	Ammo	Mode	Damage	Weight	Availability	Cost	Street Index
Shotgun	(-2)	4 (m)	SS	7S	2.25	5/48hrs	500¥	1.1

### UBS-6:

Type	Conceal	Ammo	Mode	Damage	Weight	Availability	Cost	Street Index
Shotgun	(-2)	6 (m)	SA	7S	2.5	6/48hrs	750¥	1.1

### UBS-7:

Type	Conceal	Ammo	Mode	Damage	Weight	Availability	Cost	Street Index
Shotgun	(-3)	2x 4 (m)	2x SS	7S	3.5	10/7 days	1,700¥	1.25

When not attached to another weapon, add +4 to the Target Number. These shotguns use LP ranges due to the short barrels.

For the UBS-7, each barrel can only be fired once per Combat Phase, but this does allow the character to fire two rounds, one from each barrel; remember that each barrel has its own magazine that must be reloaded separately. Like the other UBS-weapons, it uses LP ranges, and firing it when not attached to another weapon gives a +5 modifier to the Target Number.

>>>>[These UBS-things sound great to me. Staple one to your favorite assault rifle, load it up with buckshot, and blast away through the hallway or alley!]<<<<<  
—Psycho Punk (20:51:18/05-02-55)

>>>>[I must admit to PP being right for once. If you expect to run into serious trouble, you could do a whole lot worse than get yourself one of these things and mount it under your rifle.]<<<<<  
—Virtuoso (16:05:28/05-07-55)



## Sandler "Mad Max"

Taking its name from a 1980s movie trilogy, in which the main character carries a sawn-off shotgun very similar to this weapon, the Mad Max is a self-defense weapon for those with a taste for the old-fashioned. The gun looks like a full-length double-barrel shotgun with the stock and barrel sawn off, except that it was designed in this way. This feature makes it easily concealable, while the firepower provided by the two side-by-side barrels is tremendous.

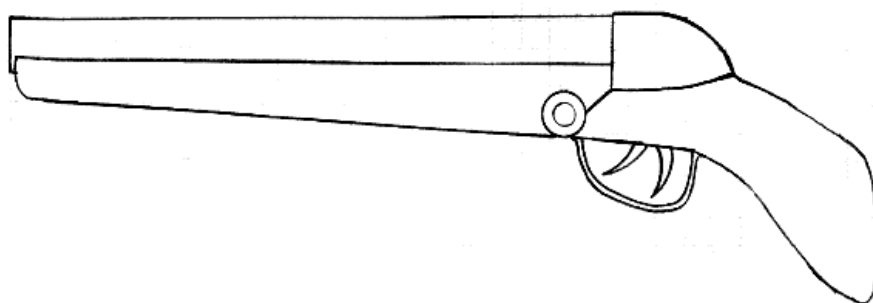

Type	Conceal	Ammo	Mode	Damage	Weight	Availability	Cost	Street Index
Shotgun	5	2 (break)	SA	6S	2.25	4/48hrs	400¥	1

Due to the short barrels, however, the Mad Max uses heavy pistol ranges. When firing buckshot rounds, the choke is not adjustable; it has a fixed choke of 5.

## Assault Rifles

### Heckler & Koch 70

New from the well-known German firm, this assault rifle is radically different from the previous G12. Instead of the bullpup design, H&K have decided to go back to the traditional "assault rifle" shape by placing the high-capacity clip directly in front of the trigger. The HK 70 is available in two versions: the basic HK 70, which features a fixed stock, and the folding-stock HK 70 K.

#### HK 70:

Type	Conceal	Ammo	Mode	Damage	Weight	Availability	Cost	Street Index
Assault	2	20/45 (c)	SA/BF/FA	8M	3.75	8/7 days	950¥	2

#### HK 70 K:

Type	Conceal	Ammo	Mode	Damage	Weight	Availability	Cost	Street Index
Assault	3	20/45 (c)	SA/BF/FA	8M	4	8/7 days	950¥	2.25

Both have a rating 2 gas vent as standard equipment, and can use 20-round and 45-round clips (45-round clip reduces Concealability by -1).

>>>>[The clip capacity is this weapon's main virtue. Otherwise, they're bog-standard assault rifles.]<<<<

—Mikey-Boy (13:05:37/05-06-55)

>>>>[Are these stats right? The folding-stock weapon is heavier than the fixed-stock one.]<<<<

—Parker (04:08:46/05-09-55)

>>>>[That's right, yeah. The fixed plasric stock weighs less than the folding metal one.]<<<<<  
 —Heavy (15:40:41/05-11-55)

**Honda AR-1**

Honda's first entry into the weapons market is an assault rifle. The design is somewhat unconventional in that it is a bullpup design with a standard telescopic sight; the bullpup design allows for a short weapon, and because of its plastic and ceramics construction it is highly concealable. Rumor says that a major Japanese corporation is arming its security personnel with the AR-1, though with some accessories that are not on the commercial weapon.

Type	Conceal	Ammo	Mode	Damage	Weight
Assault	3	28 (c)	BF/FA	8M	4.25
Availability	Cost	Street Index			
9/6 days	1,000¥	2			

Give this weapon +1 Concealability against weapon detectors. The telescope is rating 1.

>>>>[Fuchi's military assets are doing field trials with these weapons, but they not arming its security with them.]<<<<<  
 —Hiro (IW:AN:TT/HI-SG-UN)

>>>>[Yet.]<<<<<  
 —Chat (02:47:51/05-16-55)



**SIG 88x-series**

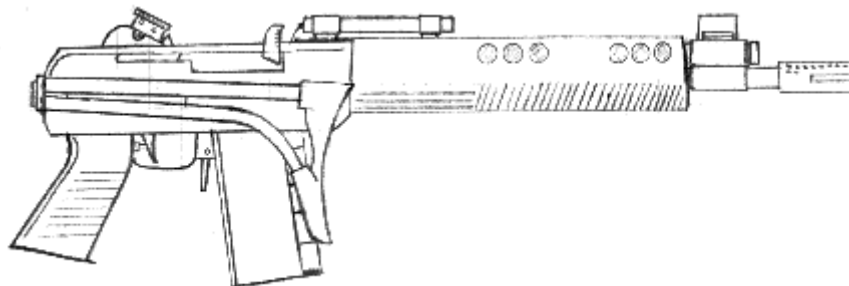

This series of Swiss assault rifles comprises four models: the 880, which is the basic assault rifle of the series; the 882, which has a shorter barrel and a folding stock; the 883, basically an 880 with a longer and heavier barrel, for use as a light support weapon; and the commercial 883 SP, similar to the normal 883, but with some modifications to allow it to be used as a civilian hunting weapon. Parts are interchangeable between weapons, but it is not possible to convert one weapon into another variant of this rifle family. The standard clip contains 30 rounds, though a 5-round clip is normally used with the 883 SP, and a 50-round drum exists for prolonged fire with the 883. All weapons are capable of using all clips.

880:								
Type	Conceal	Ammo	Mode	Damage	Weight	Availability	Cost	Street Index
Assault	2	30 (c)	SA/BF	8M	4	4/36hrs	850¥	2
882:								
Type	Conceal	Ammo	Mode	Damage	Weight	Availability	Cost	Street Index
Assault	3	30 (c)	SA/BF	8M	4	5/36hrs	850¥	2
883:								
Type	Conceal	Ammo	Mode	Damage	Weight	Availability	Cost	Street Index
Assault	1	30/50 (c)	SA/FA	9M	6.5	6/48hrs	1,000¥	2.5
883 SP:								
Type	Conceal	Ammo	Mode	Damage	Weight	Availability	Cost	Street Index
Assault	2	5/30 (c)	SA	9M	4.25	3/36hrs	950¥	1.5

The 880 and 882 both have a rating 2 gas vent mounted on the barrel, and come with a top-mounted laser sight. The 883 has a rating 3 gas vent, a top-mounted laser sight, shock pads, and a bipod. The 883 SP has no gas vent nor bipod, replaces the laser sight by a rating 2 telescope sight, but retains the shock pads.

>>>>[Any competent weaponsmith should be able to turn the 883 SP into a fully-automatic weapon by using a few spare parts intended for the normal rifles. It should cost you no more than maybe 150 to 200¥, and if you then add some accessories yourself, you have a neat automatic rifle that packs a good punch.]<<<<<

—Redhead (16:28:11/05-06-55)

>>>>[The SP is a lousy weapon. I had to fire five rounds into that deer before it went down. I'm sticking with Remington.]<<<<<

—John Waterman (19:31:05/05-09-55)

>>>>[You use it to hunt deer?!? Are you sure you're at the right SIG here?]<<<<<

—Latex Louis (23:52:01/05-09-55)

>>>>[Of course I hunt deer. What else?]<<<<<

—John Waterman (15:48:41/05-12-55)

>>>>[Is he really as stupid as he appears to be? Should we tell him what most people here hunt?]<<<<<

—Slime (18:01:55/05-13-55)



## Grenade launcher

### Rockwell AGL-113

Providing immense firepower, this Rockwell fully-automatic grenade launcher is rapidly coming into wide use among mercenary units and corporate military forces. The weapon is large and bulky, and is not suitable for hand-held firing; it is normally mounted on a vehicle or on a tripod. The vehicle-mounted weapon has no hand grips, while the infantry version comes with grips and a tripod.

Type	Conceal	Ammo	Mode	Damage	Weight	Availability	Cost	Street Index
Grenade	—	20 (c) or belt	FA*	grenade	50	24/21 days	15,000¥	4

\* = the maximum number of rounds that can be fired in a Complex Action is 8 (eight), not 10.

>>>>[Now this weapon can seriously ruin your hairdo. Some corp forces use it to protect vital installations: they load it up with a cocktail of different grenade types and hose down anyone who gets too close.]<<<<<

—Kyle (07:26:09/05-02-55)

## Heavy Weapons

### Ares MP Maser

A new breakthrough in weapons technology! The MP Maser is similar to the MP Laser III, but uses microwaves instead of laser beams. Though damage is less than that of a comparable laser system, a maser has a few advantages: armor is useless against it, unless it is made of metal; and there is a major chance of cybersystem damage to anyone hit by the maser!

Type	Conceal	Ammo	Mode	Damage	Weight	Availability	Cost	Street Index
SMG	—	20	SA	10M	25	—	750,000¥	—

The MP Maser uses submachine gun ranges and has no recoil. Anyone in a one-meter wide path from the firer out to maximum range takes damage (unless the beam is stopped by an object which it cannot damage). It is powered by a 20-shot battery, which is rechargeable and mounted on a hip-belt. Armor, if it contains metal plates or foil, uses its Impact rating to defend against a maser. Anyone hit by a maser rolls 1D6 on the following table for possible side effects:

Roll	Effect
1	1D6-1 cybersystems damaged
2	1D6-2 cybersystems damaged
3	1D6-3 cybersystems damaged
4	1D6-4 cybersystems damaged
5	1D6-5 cybersystems damaged
6	no effect

The maser is made less effective by mist and fog; for every ten meters of mist fired through, the Power Level is reduced by -1. Every five meters of light fog fired through reduces the Power Level by -1, and every three meters of heavy fog also reduces it by -1.

>>>>[The armor does not need to be fully metallic: any layer of metal will do. You can take household aluminum foil, wrap yourself in it, and you suffer no damage from a maser at all. Also, it won't damage things made up of symmetrical molecules. That means people (and other creatures) are unlucky, cause we consist mostly of water, an asymmetrical molecule.]<<<<<

—Him That Knows (16:02:34/05-08-55)

### M400 Heavy Machine Gun

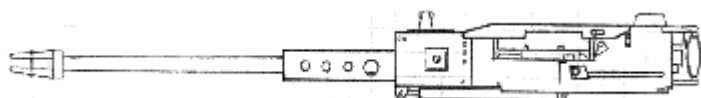

Just adopted for service use by the UCAS Army and Marine Corps, the M400 is a belt-fed fully-automatic machine gun, with a very high rate of fire. Its main virtue is the dual-feed mechanism, allowing two belts to be inserted into the weapon. The gunner can select the required belt in a Simple Action, or a Free Action if he is cybernetically controlling the weapon. It comes equipped with a rating 3 gas vent as standard, and a version with internal smartlink (level II) circuitry is also available.

**Standard model:**

Type	Conceal	Ammo	Mode	Damage	Weight	Availability	Cost	Street Index
HMG	—	2x belt	FA	10S	18.5	22/21 days	5,500¥	2

**Smartlink (II) model:**

Type	Conceal	Ammo	Mode	Damage	Weight	Availability	Cost	Street Index
HMG	—	2x belt	FA	10S	19	24/21 days	7,500¥	2.5

The M400 has a rating 3 Improved gas vent system on the barrel. It fires at super machinegun rates, for a full autofire of 15 rounds per Complex Action. Switching between belts costs the gunner a Simple Action if done manually, or a Free Action if the gun is cybernetically controlled. This does mean that a cyber-controlled gun can switch between belts while firing, but this may be done only once per Combat Phase.

Example: an M400 with smartgun circuitry is loaded with a belt of Explosive rounds and a belt of Regular rounds. The gunner fires 10 rounds, of which he decides to put four at a human coming at him, and the remaining six at the van standing behind the human. The gunner puts four regular rounds into the human, then switches to explosive, and fires the remaining six at the van.

>>>>[Dual-feed weapons are ideal for mounting in vehicles. Put in two ammo bins for the same gun, and load each with a different ammo type. The rigger simply selects the right ammo type for the right job and can use it instantly, without having to reload the gun each time he switches targets.]<<<<<

—Fix (23:16:28/05-07-55)



### Mistubishi Guardian™

The Guardian™ is Mitsubishi's all-purpose "smart" missile system, the basic weapon system having four launch tubes for normal missiles of all kinds. It is coupled to sophisticated vehicle-recognition sensors that allow it to track its target everywhere!

Conceal	Rating	Weight	Availability	Cost	Street Index
—	—	150	18/30 days	150,000¥	5

A basic Guardian™ system has Gunnery skill 4 and Initiative 10 + 1D6. It is equipped with Standard sensors (level 1, see **RBB** page 126), but higher levels can be purchased for the difference in cost between the cost of the required sensors and Standard sensors (Security I sensors cost 120,000¥ - 5,000¥ = 115,000¥). Add the sensor's level to the Gunnery skill. Treat these sensors as vehicle sensors for all intents and purposes.

Initiative can be upgraded to 15 + 1D6 for 10,000¥ and to 15 + 2D6 for 15,000¥. Each extra missile launch tube costs 1,500¥, and the Guardian™ can have a maximum number of launch tubes equal to its Sensor rating + 4. The system's Gunnery skill level cannot be upgraded. The only way to increase the hit chance is to add better sensors.

To hit a target, the Guardian™ must first acquire it. This requires the system to spend a Simple Action and make a test rolling a number of dice equal to its Sensor rating against a Target Number equal to the vehicle's Signature rating. It can acquire one target per Simple Action spent. The Guardian™ can track a number of vehicles up to its Sensor rating.

After acquiring the target, the system proceeds to fire a missile (which costs it a Simple Action per missile fired); the Target Number is calculated normally for the missile being fired (**SRII** page 99), but roll an extra number of dice equal to the number of successes scored when acquiring the target.

If the target is destroyed, the Guardian™ will switch its attention to the next target; if the target is not destroyed, it will fire another missile.



>>>>[A nasty surprise for any rigger trying to infiltrate corp turf in his vehicle.]<<<<

—Riggin Renegade (11:41:32/05-11-55)

>>>>[Look at the name: Guardian™ looks suspiciously much like Sentry™, doesn't it? Coincidence...? Yeah, sure.]<<<<

—Strung Out (05:12:55/05-12-55)

### Whitney-Morgan Caseless Machine Gun

A revolving-barrel medium machine gun, the Whitney-Morgan provides massive firepower in a small weapon! It is normally mounted on vehicles or tripods only, being too large and heavy to be hand-held, even with the assistance of a gyro-mount. The weapon fires at minigun rates, for a very lethal surprise! It cannot use stock-mounted accessories.

Type	Conceal	Ammo	Mode	Damage	Weight	Availability	Cost	Street Index
MMG	—	belt	FA	9S	35	26/30 days	25,000¥	4

(note: a picture of this weapon is given on page 239 of **SRII**, but no stats were given; presumably, it is a "typical" MMG or HMG)

>>>>[A fine weapon, if you're going anywhere a vehicle can get.]<<<<

—Wallow (22:28:38/05-03-55)

## Melee Weapons

### Mersch MX-23 Stunlance



Combining two weapons into one, the MX-23 is ideal for riot-control! This spear-like weapon is actually a taser, though its pointed end can be used to stab effectively. Since the spearhead also contains the taser contacts, you can shock your target while stabbing him! Naturally, the Stunlance can also be used to simply shock the target without doing physical damage.

Conceal	Reach	Damage	Weight	Availability	Cost	Street Index
2	2	point: (str+2)L taser: 9S Stun	3	5/48hrs	2,500¥	1

## Exotic

### Sonic Stunner

Designed by Phlatline (during astronomy class on top of that!), the Sonic Stunner uses sound waves to achieve a taser-like effect, virtually guaranteeing knockdown! It is powered by an internal battery, which can naturally be recharged. A charge provides enough energy for 10 shots, with the weapon allowing two different charge rates: quick (1 hour) and normal (8 hours). For every time the weapon is quick-charged, it loses 1 shot (after 10 quick charges, it cannot be fired anymore); for every 4 full-charges, it also loses one shot. By "cycling" the weapon for 24 hours, this degradation is undone, restoring the weapon to its full 10 shots.

Type	Conceal	Ammo	Mode	Damage	Weight	Availability	Cost	Street Index
Taser	6	10	SA	15M	2	6/36hrs	1,000¥	1.5

Living targets roll a Body Resistance Test against the damage, and are stunned for a number of turns equal to the Power, minus the target's Body rating. The target is automatically knocked down. The Stunner also shatters glass of up to Barrier Rating 3.

(credits: Phlatline designed this weapon on or around March 30, 1994, and posted it on the ShadowRN mailing list.)



## Accessories

### Gun Camera

This small camera fits to the top or under-barrel mounting of any normal firearm, taking a picture every time the weapon's trigger is pressed, allowing the firer to take pictures of his targets while they are being shot at! All pictures are 2D, but of good quality, and the camera is equipped with a chip port so the pictures can be stored on the chip. Any standard chip will fit, with each picture taking up .1 Mp of memory. Alternatively, plugging the camera into a datajack allows the user to record the pictures in his or her headware memory.

Mount	Conceal	Rating	Weight	Availability	Cost	Street Index
Top or Under	-1	—	.25	2/48hrs	300¥	.5

When using this camera to take pictures for the news (see **Shadowbeat**), apply a -6 modifier to the Impact of the pictures.

>>>>[Finally pictures I like that I can on my walls!]<<<<<  
 —Mike (04:52:23/05-08-55)

>>>>[Yeah, but what's the practical use of this thing? Shadowrunner holiday snapshots?]<<<<<  
 —Today (21:49:59/05-08-55)

>>>>["See this one, Junior? Yeah, that's the guy your grandfather chased half-way through Denver 'fore he caught him. That would be, errm, November '54, if I'm right. He took at least five rounds before he finally went down. Now where did I leave the other four pictures?"]<<<<<  
 —Dave (05:29:54/05-12-55)



### Revolver Silencer

Up until now, revolvers were impossible to silence because of the gas leakage between the cylinder and the barrel. Universal Industries has the solution: a silencer that does not simply fity onto the front of the barrel, but instead encloses the barrel *and* the cylinder! This device makes it impossible to use both the barrel and under-barrel mounts of the revolver, but this is a small price to pay for a silent revolver!

Mount	Conceal	Rating	Weight	Availability	Cost	Street Index
Barrel	-3	—	1	6/60hrs	700¥	3

Since the silencer encloses the cylinder, a revolver with such a silencer takes longer to load. A Simple Action is needed to open the silencer before loading can begin, and a second Simple Action must be spent to close the silencer again after loading.

## Smartscope

Combining telescope and smartlink technology into one accessory, the Nikon Smartscope mounts on the top-mount of virtually all weapons. The Smartscope consists of an external smartlink system, with a movable telescope attached to its top. The telescope is automatically adjusted for the correct weapon elevation, based on information provided by the smartlink. The telescope also displays all relevant information normally provided by the smartlink. Naturally, the Smartscope can be coupled to a cyberware smartlink or smart goggles, though the latter are now obsolete.

No magnification:						
Mount	Conceal	Rating	Weight	Availability	Cost	Street Index
Top	-2	-1 / 0	1	5/60hrs	3,250¥	1
Level 1:						
Mount	Conceal	Rating	Weight	Availability	Cost	Street Index
Top	-2	-1 / 1	1	5/60hrs	3,500¥	1
Level 2:						
Mount	Conceal	Rating	Weight	Availability	Cost	Street Index
Top	-2	-1 / 2	1	5/60hrs	3,750¥	1.1
Level 3:						
Mount	Conceal	Rating	Weight	Availability	Cost	Street Index
Top	-2	-1 / 3	1	5/60hrs	4,250¥	1.1

The Smartscope functions as a Level I smartlink, and gives a -1 modifier to the Target Number at all ranges. It is available in four versions: no magnification, level 1 magnification, level 2 magnification, and level 3 magnification. Low-light and thermographic options are also available for all scopes. Add 1,500¥ to the scope price for per option (low-light or thermographic).



>>>>[Finally, no longer having to wear those suspicious smart goggles!]<<<<<  
—Steel (15:44:09/05-12-55)

>>>>[This scope does have a disadvtantage: you have to shoulder your weapon to use it. With smart goggles, you don't even need to see your gun to know where your bullets will hit.]<<<<<  
—Ferret (02:42:56/05-14-55)

>>>>[If you just get yourself a smartlink implant, you don't have to bother with goggles at all.]<<<<<  
—Aunt Annie (07:31:47/05-15-55)

>>>>[You're not a mage.]<<<<<  
—Steel (14:26:50/05-15-55)

## SumnerTech Gyro-Mount 1S

Using similar shock-absorbing technology as other gyro-mounts, the 1S is an arm-mounted device instead of a full-body harness. It fits onto the under-barrel mount of almost any weapon, and is secured behind the wrist and just above the elbow by straps; the mount is designed to allow the arm full and normal movement, and can be worn underneath a wide jacket or sweater sleeve. Available in both right and left arm versions.

Mount	Conceal	Rating	Weight	Availability	Cost	Street Index
Under	-3	3	2.5	6/48hrs	2,000¥	1

The Gyro-Mount 1S negates recoil and movement modifiers up to its rating. Any action attempted with an arm onto which the 1S is mounted (except for shooting the attached gun), has a +2 modifier to the Target Number, but a succesful melee attack with the arm does (Str+1)M Stun damage.

## Ammunition & Explosives

### Anti-Armor Grenade

Available only as mini-grenades to be fired from grenade launchers, anti-armor grenades are designed to penetrate vehicle armor instead of engaging living targets. Their blast area is small, but they have an armor-piercing warhead, which means that the Damage Level is not reduced by vehicle armor, *but* this only applies to the vehicle that gets hit directly.

Conceal    Damage    Power Level    Weight    Availability    Cost    Street Index

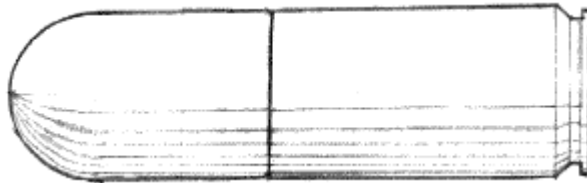

8    10S    -5 per meter    .1    8/5 days    125¥    3.5



### Claymore

The Claymore is a directional anti-personnel mine: instead of causing general mayhem and destruction, the Claymore blows a spread of ceramic balls into a 45° cone, focussing its power into a specific area! The explosive charge itself causes damage in a spherical area some 10 meters in diameter, but the ceramic balls are effective out to some 30 meters. The Claymore is remote-controlled by means of a 50-meter long wire, or can be fitted with a tripwire or a timer detonator.

Conceal    Damage    Power Level    Weight    Availability    Cost    Street Index

4    cone: 10D  
sphere: 10S    cone: -1 per 5 meters  
sphere: -1 per 3 meters    1.5    8/6 days    175¥    3

>>>>[These things are *serious* drek. Place a couple in some alley and cover them up with some garbage. When you have someone chasing you, lead them into the alley and blow the Claymores. Then pick up what's left and go and sell hamburgers.]<<<<  
—Freddy (15:42:19/05-15-55)

### CS Grenade

Very similar to smoke grenades, but with the difference that CS grenades spread CS (tear) gas instead of smoke! Perfect for riot-control and house-clearing!

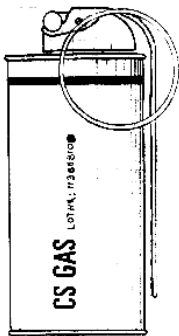

Conceal    Damage    Power Level    Weight    Availability    Cost    Street Index

5    —    ----    .5    6/4 days    75¥    2.5

These grenades use the rules for smoke grenades (page 85, FOF), but everyone in the cloud gets a +8 modifier to all Target Numbers due to the gas. Characters with their eyes shielded (or with cybereyes) get +4, while people with their mouth shielded (and those who hold their breaths) get +6. If both the eyes and mouth are shielded, the modifier is only +2 due to the gas touching the skin. People in gas-proof suits get no modifier. All these modifiers are in addition to the normal modifiers for light smoke (SRII page 89).

## Duplex Ammo

Fitting two rounds into one cartridge case, duplex ammunition gives you a higher chance of hitting simply by putting more rounds into the air! Add that to the chance of both rounds striking the target, you also have the potential of doing greater damage!

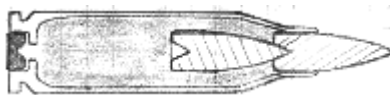

Conceal	Damage	Weight	Availability	Cost	Street Index
8	see above	.75	5/36hrs	90¥	1

When firing Duplex rounds, add a -1 modifier to the Target Number at Medium and Long range, and +1 at Extreme range (the rounds drop faster than normal ammunition, so at longer ranges it is more difficult to hit). If a hit is scored, roll 1D6/3 for every Duplex round fired; the result is the number of bullets that hit, and then simply treat the hit as a burst of the number of bullets that hit. Recoil is, as normal, +1 per round fired.

For example: Jane Samurai fires a three-round burst of Duplex at Joe Mage, using a smartlinked 7M damage SMG with a rating 2 gas vent; Joe is at Medium range, which sets the Target Number at 5; the recoil of the 3-round burst makes this 8, -2 for the Smartlink, and another -1 for the Duplex ammo at Medium range. Her Target Number is 5; she rolls a total of 7 dice, scoring 3 successes. She hits, and now rolls 3D6/3 (she fired a three-round burst); on the 3D6, she rolls 4, 2, and 6, which converts to 2, 1, and 2, this means that five bullets hit (2+1+2=5). The damage is 7M, plus 5 for the five bullets, for 12D in total. Had she fired Regular ammo, her Target Number would have been 6, and the damage would only have been 10S for the three-round burst.

>>>>[Great stuff! Double your rate of fire!]<<<<<  
 —Psycho Punk (21:10:51/05-02-55)



## Firepower™ Ammo

From Ares Arms comes heavy pistol ammunition that puts new life into your old-reliable! Couple that with the redesign of the Predator heavy pistol, and Ares once again asserts its dominance of the market. No other manufacturer even comes close!

Conceal	Damage	Weight	Availability	Cost	Street Index
8	+1 Power	.5	3/36hrs	35¥	.75

(note: this ammo was in the first edition Street Samurai Catalog, but it was dropped in SR2. The reason for this was that it was designed "to balance the game for heavy pistols," but in SR2 the base damage codes were adjusted, so the ammo was no longer needed. Originally, it gave +2 Power (making your 4M2 heavy pistol go up to 6M2); here I have given it +1 Power, making it equivalent to Explosive rounds, but without the associated noise. It is only available for heavy pistols, though. The Ares Predator II is already adapted to fire this ammo, though its Damage Code does not yet reflect this.)

>>>>[You can easily modify your current heavy pistol to use the Firepower ammo. Take any heavy pistol to your local weaponsmith and have him rebores and refit the weapon to accept the new ammunition. It won't cost you more than 60 to 80¥.]<<<<<  
 —Winger (10:06:04/12-23-50)

## Gas Grenade

Winter Systems supplies these Neuro-Stun VIII grenades, as used by counter-terrorism units and police forces. They are highly effective to "smoke out" entrenched opposition, and can be supplied in hand-thrown or grenade-launcher models!

Conceal	Damage	Power Level	Weight	Availability	Cost	Street Index
5	—	—	.5	5/4 days	60¥	2

These grenades spread Neuro-Stun VIII gas in a similar way to a smoke grenade (see SRII page 186 and FOF page 85).

(note: this grenade was in the first edition Shadowrun rules, but was not included in the second edition.)

>>>>[Gas the fraggers.]<<<<<  
 —Willy Wonka (20:01:43/05-12-55)

### Glaser™ Ammo

Patented by the Glaser Company, these anti-personnel rounds are devastatingly effective! When the bullet hits a target, it ruptures and spills its contents of small metal balls onto the target, giving off an enormous amount of energy! Available for all weapon types up to and including light machine guns.

Conceal	Damage	Weight	Availability	Cost	Street Index
8	+2 Damage	.75	16/14 days	100¥	4

These rounds increase their Damage Level by +2 against unarmored targets only. If the target has any kind of armor (Ballistic or Impact), use the highest armor rating present and double it to defend against these rounds. In a similar manner, when firing through cover, double the cover's Barrier Rating. The +2 Damage Level increase is also not used against vehicles.

>>>>[Studies have shown that only 10% of all people shot with handgun rounds have died from their wounds. On the other hand, only 10% of all people shot with Glaser rounds have *lived* to tell about it... They were developed as anti-terrorism rounds, and are hideously illegal for civilians to possess in most jurisdictions. UCAS rates them as class 1-L military ammo.]<<<<<

—Gurth (!@:#\$:%^/&\*-( )-+\_)



### Hollow Point Ammo

Increased damage potential at low cost!

Conceal	Damage	Weight	Availability	Cost	Street Index
8	+1 Damage +2 Ballistic	.5	3/24 days	30¥	1

Hollow point rounds have an opening in the front of the bullet, which causes them to expand when hitting their target. This does much more damage than regular rounds, but with the disadvantage that armor is more effective because the expanded bullet has a higher frontal area. Hollow point rounds increase the Damage Level by +1, but any Ballistic armor worn gets +2 to its rating to defend against them.

### Scatter Grenade

Instead of blowing up just once, scatter grenades by Winter Systems of Manhattan have multiple explosive charges! After throwing, the grenade's body springs open and releases three charges, each of which scatters randomly before exploding! Three different charges are available: Concussion, HE, and Smoke; the customer specifies which and how many of each charge are in the grenades purchased. Charges cannot be purchased separately, nor can a thrown grenade be reloaded.

**Complete grenade:**

Conceal	Damage	Power Level	Weight	Availability	Cost	Street Index
5	charge	charge	.5	6/5 days	100¥	2.25

**Concussion charge:**

Damage	Power Level
8M Stun	-1 per meter

**High Explosive charge:**

Damage	Power Level
7S	-1 per meter

**Smoke charge:**

Damage	Power Level
—	—

To use a Scatter Grenade, use all normal grenade rules. The grenade itself scatters as normal (SRII page 97), but at the moment it would normally explode, it throws out three charges; each of these charges flies 2D6 meters away in a random direction. They explode immediately. The smoke charge covers only a 5-meter radius area, but otherwise uses all rules for smoke grenades on page 85 of FOF).

>>>>[A bit random for my taste.]<<<<  
—Jarvis (15:37:51/05-04-55)

>>>>[But you can't deny the advantages of these grenades. Three charges that explode at different points cause much more chaos than just one. Mix and match to get exactly the combination of explosives and smokescreens you want. I've used these grenades a few times and they're excellent to create havoc everywhere.]<<<<  
—FFG (03:59:48/05-08-55)

### Shaped Charge

Lining the explosive behind a copper cone, these all-new shaped charges are in use with counter-terrorism force world-wide! The sticky back surface allows them to be attached virtually anywhere, at optimum stand-off distance without need for careful study of the wall, and thus without wasted time! The detonator features adjustable count-down time (from 1 second to 1 hour), and has a remote-control setting. It is even possible to set both at once!

Conceal	Damage	Power Level	Weight	Availability	Cost	Street Index
4	15D	-5 per meter	1	12/48hrs	500¥	2.5

Placing these charges is easy enough, but if the character placing them makes a Demolitions skill test (Target Number 2), add his successes to the Power Level as applied to the barrier.

>>>>[Excellent all the way. If you don't mind making noise as you go in, stick one of these to the wall and get in without bothering with doors!]<<<<  
—Hairy Harry (21:40:52/05-10-55)

>>>>[Or, get in without making noise and use these to secure yourself an exit before you go on.]<<<<  
—She (05:38:29/05-13-55)



## Gear

### Armament Briefcase

Looking like a standard executive briefcase, but in fact concealing any single weapon up to SMG size, this is a nasty surprise for any attacker. The briefcase's detachable handle is attached to the top mount of a weapon, and the briefcase is then closed over the weapon. Upon pressing a button on the handle, the briefcase falls off the handle, revealing the concealed weapon, ready for immediate use! Ideal for bodyguards!

**Handle only:**

Mount	Conceal	Rating	Weight
Top	(-2)	—	.25

**Whole assembly:**

Conceal	Rating	Weight	Availability	Cost	Street Index
—	(0/2)	1.5	4/36hrs	500¥	2

Drawing a weapon from this briefcase counts as quickdrawing a weapon. The weapon cannot be fired when it is inside the briefcase, but can be carried fully-loaded and ready to fire. Inside the briefcase is enough room to store small things in addition to the gun (GM's decision), but these fall out when the weapon is drawn. The briefcase is made of tough impact plastic, giving it armor ratings Ballistic 0, Impact 2.

>>>>[And you thought all those suits were carrying was paperwork...?]<<<<  
—Wiley (08:28:22/05-07-55)

### Fire-Resistant Coveralls

As worn by military vehicle crews, fire-resistant coveralls are now available to the general public! Made from Nomex-B™, these suits cover virtually the entire body to protect it from fire and heat! Available in Desert and Woodland camouflage colors, as well as olive green, and blue.

Conceal	Ballistic	Impact	Weight	Availability	Cost	Street Index
10	0	3	3.5	10/48hrs	2,000¥	1

The Impact armor rating is only used against fire- and heat-related damage. The suit provides no protection from other kinds of "attacks," but use their full Impact rating to defend against fire and heat. Against cold, the suit is not effective (Nomex is fire-resistant, not insulating). Against magical fire from Combat spells, the suit provides no protection, but against fire from Manipulation spells, it uses its full Impact rating to defend.

### Kelmar Police Armor

A new line of body armor developed especially for everyday police use in all major sprawls. The line stresses impact protection, as opposed to protection against firearms, for the reason that most policemen are attacked with improvised weapons at close range, instead of with firearms. The armors are revolutionary in including gel-packs as standard, and are manufactured in police colors only. The helmet has a built-in radio, and a visor that protects the upper part of the face. For an additional 1,500¥, the visor can function as a set of smart goggles.

	Conceal	Ballistic	Impact	Weight	Availability	Cost	Street Index
Light	2	3	5	2.5	20/14 days	10,000¥	3
Heavy	1	5	7	4	24/20 days	12,500¥	3.5
Helmet	—	+0	+1	.75	20/14 days	2,000¥	3.5

>>>>[This armor is coming into use with NYPD Inc. You know what to expect the next time you visit New York City.]<<<<<  
 —Pro Tector (14:03:11/05-08-55)

### Sneak Suit

Popular with corp strike teams and special forces, this suit is covered in ruthenium polymers, mimicing the background against which it is viewed! When turned off, the suit is black, and can be used for night camouflage. The suit resembles the skin-tight suits worn by speedskaters, but with gloves, foot covers, and a mask covering the lower half of the face. Any equipment worn over the suit is, naturally, not camouflaged.

Conceal	Ballistic	Impact	Weight	Availability	Cost	Street Index
+4	0	0	2	8/14 days	50,000¥	7.5

When switched on, the suit gives a +4 modifier to all Target Numbers to spot the wearer.

>>>>[The next best thing to an Invisibility spell.]<<<<<  
 —Chat (07:12:36/05-05-55)



## Superball

Superball is a nasty "smart" plastic that is used as a restraint. It consists of a plastic strip that fuses to itself when pressed together; it is put around the subject's wrists and pressed together. When the subject tries to pull himself free, or in some other way tries to break the restraint, the plastic tightens itself,

If the Superball is cut, the remaining end will tighten up: this means that, if it is bound around both wrists, one of the wrists is bound off when the other end is cut.

The name Superball comes from the fact that the plastic, after it has been cut, tightens itself up into a ball.

Conceal	Rating	Weight	Availability	Cost	Street Index
—	1 to 10	—	(rating x 2)/48 hrs	rating x 50¥ per meter	3

Superball tightening itself does (rating+2)M damage, against which no armor protects (unless the restraint is put over armor clothing, in which case Impact armor reduces the Power Level, GM's decision). If the Superball is cut off one wrist, the subject takes this damage every turn, until the other wrist is also cut free.

**Source note:** for Gibson fans, this is my representation of the stuff Skinner, Yamazaki, and Chevette are tied up with in Virtual Light.)

>>>>[This is extremely vile stuff. It is outlawed in all nations in North America save Tir Tairngire, but lots of corps still use it, as do all kinds of shadowy figures.]<<<<<  
 —Him That Knows (17:41:35/05-08-55)



## Thermographic Camouflage Dye

Wearing camouflage clothing is not enough these days: all those people walking around with thermographic vision will still spot you no matter how good your camouflage. So, what's the next logical step? Using this dye to distort your IR signature, of course! Most clothing can be supplied with this camouflage dye already incorporated, though at double the normal cost. By throwing a dose of this dye in your laundry, you can also do it yourself! Each dose is enough to color one piece of clothing (very large size clothing may need more doses to be effectively camouflaged).

Conceal	Rating	Weight	Availability	Cost	Street Index
—	+4	—	6/24hrs	20¥	1

The stats above are for one dose. A character wearing clothing dyed with a thermographic camouflage dye always counts as wearing appropriate camouflage (p.77, **FOF**) when viewed with thermographic vision only, no matter the environment or color of his clothing. Characters using a combination of thermographic and normal vision (trolls and dwarfs for instance) get only a +2 modifier to spot the camouflaged character.

## Vehicles

### Chrysler-Nissan Python Turbo

Chrysler-Nissan finally release an all-new vehicle, and a sports car at that! The Python only comes in a Turbo variant, and is a simple but luxurious two-seater. Standard extras include leather upholstery, roll bars for added safety, and a full stereo system.

	Handling	Speed	B/A	Sig	Apilot	Cost
Python	3/8	65/195	2/0	3	2	85,000¥
<b>Seating:</b>	Twin bucket seats		<b>Access:</b> 2 standard			
<b>Economy:</b>	25 km per liter		<b>Fuel:</b> MultiF/45 liters			
<b>Storage:</b>	2 CF underseat					
<b>Accessories:</b>	Roll bars, Turbocharger (1)					

### Eurocar 3000

Announced some four years ago, the 3000 has finally arrived! It is similar to the very successful Westwind 2000, but smaller, and also has a lower price tag. It has all the 2000's extras, except for the lock-down wheel covers, which are not generally considered a success, plus it uses a multi-fuel engine for better economy and lower fuel cost. A convertible\* version is also available.

	Handling	Speed	B/A	Sig	Apilot	Cost
Eurocar 3000	3/8	60/180	2/0	3	3	75,000¥
<b>Seating:</b>	Twin bucket seats + bench		<b>Access:</b> 2 standard			
<b>Economy:</b>	35 km per liter		<b>Fuel:</b> MultiF/40 liters			
<b>Storage:</b>	4 CF trunk					
<b>Accessories:</b>	APPS™					
* = 3000 Convertible: Access 2 standard + open top, Cost 80,000¥						



## Fledermaus PKF40 Ausf. B

The Fledermaus is a small, one-person attack VTOL. It has a semi-aerodynamic shape, and uses powerful jet engines for propulsion, four facing downward and one to the rear. This makes it much noisier than an equivalent helicopter, but also makes it possible to achieve speeds impossible to reach with modern helicopters.

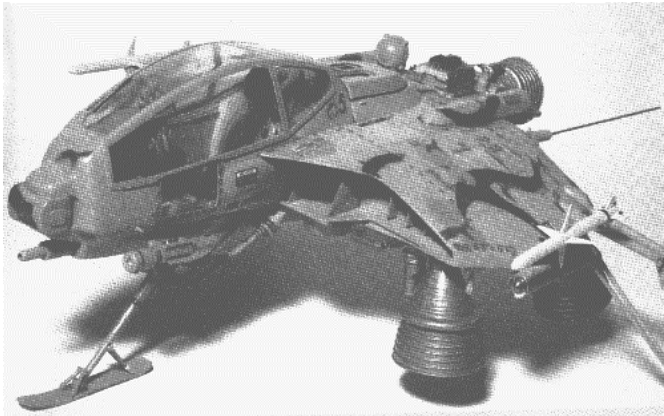

left of the minigun.

In the nose is an extensive sensor/ECM/ECCM suite, under the nose is a fixed Vanquisher minigun while the wingtips can accommodate a variety of external weapons. There is also the possibility of mounting a rocket or missile underneath the cockpit, just to the

	Handling	Speed	B/A	Sig	Apilot	Cost
Fledermaus	3	440/880	3/1	4	4	2.5M¥
<b>Seating:</b>	1 Bucket seat (ejection)		<b>Access:</b> full canopy			
<b>Economy:</b>	.25 km per liter		<b>Fuel:</b> 2,500 liters			
<b>Storage:</b>	1 CF underseat					
<b>Sensors:</b>	Military I (6)		<b>ECM/ECCM:</b> Military I (4)/Security III (3)			
<b>Landing/Take-off Profile:</b>	VTOL/VTOL					
<b>Accessories:</b>	Fly-By-Wire system (2), Vanquisher minigun					

The Vanquisher is mounted on a forward-facing Hardpoint, with 1 CF of dedicated ammo storage; each wingtip; and the under-fuselage mounting point is also a Firmpoint.

>>>>[This is a nice little machine, and it is definitely one you shouldn't underestimate. It's used by some corp security forces for rapid response (and with this baby's speed you can respond *rapidly*), and also by corporate military units.]<<<<<  
—Nighthare (04:23:48/05-14-55)

>>>>[I had the pleasure of flying one of these things at speed through Hell's Kitchen a while ago, and it handles like a dream. Altitude about two to four meters at full throttle, and still you're able to take those tight inner-city corners with room to spare!]<<<<<  
—Einzelstern (16:44:10/05-16-55)

>>>>[I hear Knight-Errant has these things in limited service already. They apparently fit them with a Victory cannon and 7.62cm rockets, but don't ask me what they're planning to do with them. Anyone have any ideas?]<<<<<  
—Jane Doe (18:50:21/05-16-55)



## McDonnell Douglas C111

A multi-purpose helicopter, the C111 is available in a number of variants, all of which share the same basic structure. The helicopter has a standard-size door on the left, and a double-size door on the corresponding position on the aircraft's right. On the left side, in the rear compartment, is also an escape door.

	Handling	Speed	B/A	Sig	Apilot	Cost
C111	4	120/275	3/4	3	3	750,000¥

**Seating:** Twin bucket seats

**Access:** standard + double-sized

**Economy:** 2 km per liter

**Fuel:** IC/1,000 liters

**Cargo:** 9 CF storage

**Landing/Take-off Profile:** VTOL/VTOL

**Options:** The Commuter layout has twelve bucket seats, in the rear compartment, in a 1-aisle-1 layout; each bucket seat has a window. The Executive model has six bucket seats in a lounge-style layout with large windows on both sides of the helicopter. The Security model has seating for ten on benches lining the rear compartment sides, and is armed with a chin Micro-Turret, two forward-facing Firmpoints, and has a window in the left side of the rear cabin; this window comes equipped with a pintle mount firing to the left of the aircraft.

>>>>[This helicopter is not sold much for commuter or executive transport. Most are of the "security" variant, and usually carry an HMG in the chin turret, coupled to an LMG on the pintle mount and rockets and missiles on the firmpoints.]<<<<<

—Riggin' Renegade (12:04:58/05-11-55)



>>>>[S.W.O. wrote this in their SWO Guns file:

```
##### # ## # ##### Students
# # ## # # # for
##### # ## # # # War &
# # ## # # # Oppression
##### ##### =====
```

presents:

GUNS! GUNS! GUNS!

The weapons in (...) this compilation were created/converted by Matt McCormick, Mike Loseke and the members of SWO. They are presented here solely for the purpose of enhancing the variety of firearms in FASA's Shadowrun. Since FASA has been lax in putting out any new weapons of substance since the Street Samurai Catalog, we've decided to post some of our own. We hope you enjoy them.

(...)

Authors: Mloseke@Lamar.ColoState.Edu Minister of Death  
 McCormick@Lamar.ColoState.Edu Grand PooBah of SWO

(...)

SWO is: Matt McCormick, Mike Loseke, Shawn Loseke, James Davis, Jason Schock, Mark Harp, Gary Harp, Marc Coulson, Phil Hull, Bryon Kerbs, Dan Black, Jason Verkuyl, Travis Menefee, Adam Menefee, John Rust, and Fuzz the cat.

For those who don't yet have them, I have added the stats and descriptions of all original weapons SWO included in the first part of the file. I pasted the pictures to the text to make it all a bit more interesting, replaced the stats bar by the one used throughout the rest of **Running Gear**, and generally altered the lay-out a bit, but I didn't make any real changes to the text or stats. Honest. Anyway, thanx to SWO for putting together that file. Oh, and what about Fields of Fire?]<<<<<  
 —Gurth (12:34:56/78-90-AB)

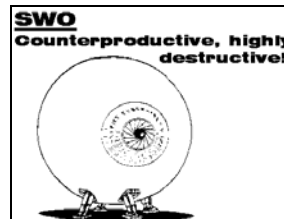

## Hold-Out

### Ceska Diplomat

New for '54, the Ceska Diplomat revolver is a perfect self defense option for the executive with a need for subtlety. Its slim design and smooth lines give it excellent concealability. The most effective feature of this gun, however, is that it has two barrels and it can fire them both at once. This added firepower, combined with the fact that it has follow up shots, leaves the Diplomat a definite contender in the growing hold out pistol market.

Type	Conceal	Ammo	Mode	Damage	Weight	Availability	Cost	Street Index
Hold-out	8	6 (cy)	SS	4L	.5	3/12hrs	250¥	1

For game purposes treat the double shot as a shortened burst.

>>>>[I have used this weapon successfully on several occasions. It packs good firepower but has a tendency to jam on the third double fire so watch it chummers.]<<<<<  
 —Debutante (05:14:30/01-13-54)

## Light Pistol

### Seco Quickfire

Ideal for bodyguards and light to medium security detail, the Seco Quickfire features good concealability, an integral laser sight and full automatic fire. This weapon gives anyone massive firepower in a small light package.

Type	Conceal	Ammo	Mode	Damage	Weight	Availability	Cost
Light	5	18 (c)	SA/BF/FA	6L	1.5	5/24hrs	750¥
<b>Street Index</b>							
2							

>>>>[Can anyone say lead hose? This weapon will empty its clip before you know it. Carry lots of spares.]<<<<<  
 —Blue Ice (13:24:06/03-12-54)

>>>>[That is if it doesn't jam first. My model didn't work for drek. So I gave it to our mage. He sure won't use it.]<<<<<  
 —8-Ball (01:13:52/04-11-54)

>>>>[Are you implying that mages can't shoot? If so, I'd sure like to meet you in a firefight 'cause I'd live, you wouldn't.]<<<<<  
 —Hurricane (23:04:12/04-21-54)

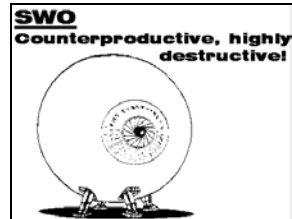

## Heavy Pistols

### Beretta 100S

Smooth lines, excellent accuracy, and deadliness all define this new heavy pistol from Beretta. Featuring a removable silencer, laser sight and classy looks, this gun is fast becoming a favorite for corporate security and "Company Men" worldwide. Also available in a smartgun variant.

Standard model:

Type	Conceal	Ammo	Mode	Damage	Weight	Availability	Cost	Street Index
Heavy	5	15 (c)	SA	9M	2.5	5/36hrs	650¥	1.5

Smartgun variant:

Type	Conceal	Ammo	Mode	Damage	Weight	Availability	Cost	Street Index
Heavy	5	15 (c)	SA	9M	2.5	5/36hrs	1,300¥	1.5

>>>>[Not style over substance, style WITH substance.]<<<<<  
 —Hunter (21:43:24/10-13-54)

### Bond & Carrington MP-11

Made in the same factory as their famous custom designer guns, this heavy personal defense option is designed to fill the gap between Bond and Carrington's extravagant custom guns and their more down to earth IWS counterparts. This machine pistol is loaded with standard features, which include, Gas Vent 2, integral laser sight or smart variant, detachable shoulder stock, and 30 round extended magazine. This gun may seem expensive, but it does allow the common man to own a bit of a legend in firearms.

Standard model:

Type	Conceal	Ammo	Mode	Damage	Weight	Availability	Cost
Heavy	4	15/30 (c)	SA/BF	9M	3	8/36hrs	1,200¥

Street Index

2

Smart variant:

Type	Conceal	Ammo	Mode	Damage	Weight	Availability	Cost
Heavy	4	15/30 (c)	SA/BF	9M	3	8/36hrs	2,000¥

Street Index  
2

>>>>[After using this weapon for several months I have to say that sans magic this is the best personal defense option I have ever used.]<<<<<

—Hurricane (13:26:04/03-10-54)

>>>>[You were right, Hurricane, I guess I'll have to listen your non-magical advice more often! This little number is great!]<<<<<

—Nitro (12:49:51/5-11-54)

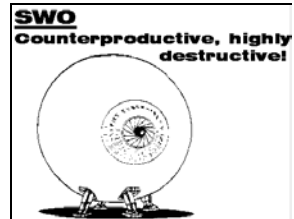

## Browning Defender 10

With the machine pistol market growing at a tremendous rate, Browning enters the fray with the Defender 10. Using a powerful but controllable round, the Defender strikes a good balance between recoil and cyclic rate. Given its reliability and resistance to adverse climates, this is an excellent candidate for military service. Of course, this makes it all the better for civilian use. Also available in a smart variant.



Standard model:

Type	Conceal	Ammo	Mode	Damage	Weight	Availability	Cost	Street Index
Heavy	5	15 (c)	SA/BF	9M	2	5/36hrs	900¥	2

Smart variant:

Type	Conceal	Ammo	Mode	Damage	Weight	Availability	Cost	Street Index
Heavy	5	15 (c)	SA/BF	9M	2	5/36hrs	1,800¥	2

>>>>[You can dunk this in toxic waste and it will still fire reliably. The recoil is manageable, but could use gas vent, and it hits like a truck. Get one if you need compact firepower.]<<<<<

—Prophet (15:12:55/12-25-54)



## Colt Penetrator

Given their success with the Manhunter, Colt designed yet another heavy pistol for the general market. This weapon, like its predecessor, is known for its reliability and firepower. Given Colt's success with the Manhunter, this gun should sell well.

Type	Conceal	Ammo	Mode	Damage	Weight	Availability	Cost	Street Index
Heavy	5	12 (c)	SA	9M	2	4/24hrs	600¥	1.5

>>>>[I \*like\* it!]<<<<<  
 —Bunker (16:32:56/9-29-54)



## Fichetti Hurricane

Another excellent security gun from Fichetti. This gun was designed with firepower and concealability in mind. It uses flechette ammo for effective takedown capability, and combines it with a removable stock and burst fire mode. Also available is an optional 30 round extended clip. A must for any security team.

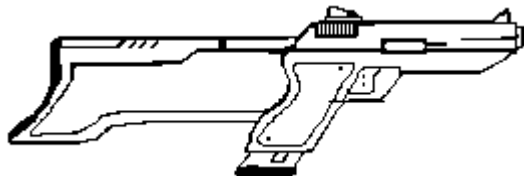
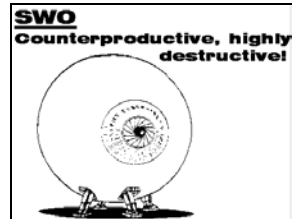

Type	Conceal	Ammo	Mode	Damage	Weight	Availability	Cost	Street Index
Heavy	5	14/30 (c)	SA/BF	9S(f)	2	3/48hrs	600¥	1

>>>>[My favorite back-up weapon. No foolin'. Good capacity, great firepower, auto-fire, low weight, easy to replace.]<<<<<  
 —The Mapmaker (17:32:45/03-22-54)

## Fichetti Military XI

Officially adopted by the CAS military in 2052, This extremely effective machine pistol has found its way to the personal defense market. Using a very powerful round and gas recoil dampening (Rating 1) this weapon delivers devastating punch with reliable accuracy. Comes standard with an integral laser sight and is also available in a smart variant.

Standard model:

Type	Conceal	Ammo	Mode	Damage	Weight	Availability	Cost	Street Index
Heavy	4	18 (c)	SA/BF	9M	2.25	5/36hrs	900¥	2

Smart variant:



Type	Conceal	Ammo	Mode	Damage	Weight	Availability	Cost	Street Index
Heavy	4	18 (c)	SA/BF	9M	2.25	5/36hrs	1,800¥	2

>>>>[I have had the opportunity to fire one of these; I found it very controllable and accurate even in burst fire. If you can get one, do so.]<<<<<  
 —The Highwayman (05:12:32/01-12-54)

### Heckler & Koch OHWS (Offensive Handgun Weapon System)

In the early 1990's, the government of old wanted a new weapon system to replace several different weapons currently in service in the armed forces' SOCOM (Special Operations Command). It needed to be able to withstand the different environments that SOCOM units sometimes operated in; salt water, desert and extreme cold were just a few. Well, the Pentagon got what it wanted; a large, indestructible, semi-automatic pistol with integrated electro-optics. With their innovative Polymide frame design, some of which exists in today's weapons, H&K were able to cut recoil forces down to less than 16% of that of a 9mm pistol.

The OHWS is made up of the following components: polycarbonate frame semi-automatic pistol, an incredibly effective sound-suppressor, a single-action/double-action trigger assembly, and an under-barrel optics system made up of a flashlight, visible light laser and an IR laser.

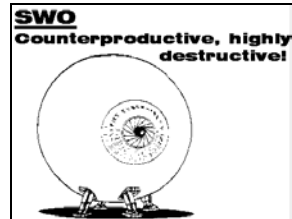

Type	Conceal	Ammo	Mode	Damage	Weight	Availability	Cost	Street Index
Heavy	5	12 (c)	SA	9M	1.2	18/14 days	2,500¥	2

>>>>[Yep, chummers, this is definetly the best 5,000¥ I ever spent. The sound-suppressor is so effective that it doesn't even sound like a pistol anymore! More like a low bass sound. And the recoil is almost non-existent! You can empty the clip in 2.5 seconds and keep the group in a 10cm circle. Well maybe not \*you\*, chummer, but I've done it.]<<<<<  
 —Prophet (14:23:12/12-21-54)

>>>>[Just like I thought: an old gun fer an old-timer!]<<<<<  
 —Bunker (18:54:33/12-24-54)

### Ingram Mk IV



This compact machine pistol was designed specifically for the UCAS security branches (FBI & NSA). It chambers a round designed during the 1990's that has been a hallmark of handgun firepower. This pistol was designed to either kill or knock down any target using not only the firepower of the round, but also a special High Explosive Squash Head round that gaurantees knockdown, as well as destroys armor. Featuring an integral smartgun link and gas vent 3, this weapon is a deadly addition to the armories of UCAS government agents.

Type	Conceal	Ammo	Mode	Damage	Weight	Availability	Cost	Street Index
Heavy	4	16 (c)	SA/BF	10M	3	18/14 days	2,500¥	3

**Game notes:** This weapon suffers double recoil penalties when used in burst fire mode. See the **Ammunition** section (page 47) for details on the HESH ammunition.

>>>>[DO NOT get in front of these things. They will kill or wound you no matter how much armor you wear, and the FBI agents can use them very well. Also, if you manage to get one, don't flash it around because the FBI/NSA don't like people having these.]<<<<<  
 —Victor (23:12:59/03-13-54)

## Ruger P-105

Ruger's most recent entry into the heavy pistol market. The P-105 uses the already successful round made famous by the Super Warhawk. The heavy firepower, combined with the fire rate, and clip capacity of an automatic makes this one of the deadliest autos on the streets. Don't be outclassed out there, get your's today.

Type	Conceal	Ammo	Mode	Damage	Weight	Availability	Cost	Street Index
Heavy	4	10 (c)	SA	10M	2.5	4/24hrs	600¥	1

>>>>[This weapon packs the best firepower in a small package that I have ever used. I carry two with me almost all the time. The only problem is it's ammo capacity (that's why I need two).]<<<<<

—Regis (07:45:12/03-12-54)

>>>>[You actually need two? One target, one shot chummer.]<<<<<

—Victor (11:23:34/04-12-54)

>>>>[I have more people after me than you do, so I use a lot of ammo. ]<<<<<

—Regis (12:45:21/04-13-54)

>>>>[I doubt it.]<<<<<

—Victor (23:12:03/04-15-54)

>>>>[And its BIG, too!]<<<<<

—Bunker (21:42:23/05-12-54)

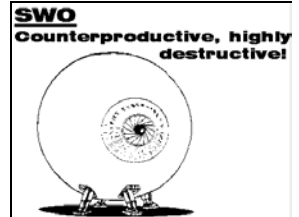

## Submachine Guns

### Defiance AT-900

Usually sticking to shotguns and tasers, Defiance has branched out into the SMG market. Its many modern features make it competitive in this very tough section of the firearms market. Standard features include: gas vent 2 and a laser sight. Optional features include smartlink, and a folding stock (100¥).



**Standard model:**

Type	Conceal	Ammo	Mode	Damage	Weight	Availability	Cost
SMG	4	30 (c)	SA/BF/FA	6M	3.75	5/36hrs	900¥

Street Index  
1

**Smartlinked model:**

Type	Conceal	Ammo	Mode	Damage	Weight	Availability	Cost	Street Index
SMG	4	30 (c)	SA/BF/FA	6M	3.75	5/36hrs	1,800¥	1

**Heckler & Koch MP-9**

This new Heckler & Koch submachine gun is a dedicated compact assault weapon. Its small size and heavy firepower make it ideal for small scale covert operations and hostage rescue teams. Its standard features include a folding stock, gas vent 3, and integral smartgun link.

Type	Conceal	Ammo	Mode	Damage	Weight	Availability	Cost	Street Index
SMG	4	25 (c)	SA/BF	7M	3.75	5/36hrs	900¥	1

>>>>[It's small size and lower recoil makes it a great weapon of choice for us 'runners of the fairer sex.]<<<<<  
 —Nitro (16:05:49/7-18-54)

>>>>[Yeah, well this member of the "fairer sex" can probably bench press you and your Westwind! I think I can handle the "manly assault weapons"!]<<<<<  
 —Cherry (12:32:45/7-19-54)



**Sandler Model II**

Sandler's second entry into the firearms market. The model II is a much improved step up from the TMP. It is not prone to frequent breakdowns like its predecessor and is reliable in all climates. It comes standard with an integral laser sight and gas vent 2.

Type	Conceal	Ammo	Mode	Damage	Weight	Availability	Cost	Street Index
SMG	3	30 (c)	BF/FA	6M	3.75	4/24hrs	700¥	1

**Walther S900**

Designed especially for security teams, the Walther S900 is a light and deadly SMG. Featuring a large magazine capacity, laser sight, and gas vent recoil suppression (level 2), this firearm is a great addition to any security team's arsenal.

Type	Conceal	Ammo	Mode	Damage	Weight	Availability	Cost	Street Index
SMG	4	30 (c)	SA/BF	6M	3	5/36hrs	900¥	1

>>>>[This weapon is small enough that you can use one in each hand. That is, if you can handle it chummer. Sleek.]<<<<<  
 —Shamrock (14:27:54/12-05-54)

**Sniper Rifle**

**Heckler & Koch PSG-65**

This advanced weapon is the new sniper rifle of Tir Tairngire. It chambers the now common sniper rifle round and builds around it a marvel of advanced firearms design. With no optional features, this rifle utilizes gas vent 2, integral smartgun link, and mag optics level 3 with integral lowlight and thermographic circuitry.

Type	Conceal	Ammo	Mode	Damage	Weight	Availability	Cost	Street Index
Sniper	N/A	20 (m)	SA	14S	6	12/7 days	7,000¥	4

>>>>[Now really, we elves wouldn't use such a nasty weapon as this, would we?]<<<<<  
 —Flash (01:27:54/11-23-54)

>>>>[Oh no! Of course not! (Feel the sarcasm drip offa that one.)]<<<<<  
 —Hunter (02:24:21/12-24-54)

## Shotguns

### Ares Wippet

Ares comes at us again with this somewhat exotic personal defense weapon. A twin barrel shotgun that loads from an underbarrel box magazine, for that extra edge in self defense. Both barrels can be fired simultaneously, but Ares discourages those who are lighter in build not to do so as the recoil can be a bit much for some.

Type	Conceal	Ammo	Mode	Damage	Weight	Availability	Cost	Street Index
Shotgun	4	6 (m)	SA	shot: 6M slug: 9M	2	5/36hrs	1,500¥	1.5

>>>>[I came across one of these cuties on a run recently; the poor slob tried takin' my head off with both barrels: the recoil pert' near took his hand off. I keep it in the car in case I ever get \*really\* desperate. Nice compact man-stopper, tho.]<<<<<

—Prophet (22:21:53/8-22-54)



### Chandler Capture 100

An excellent assault shotgun. It has been used by many different police forces in seizure raids to great satisfaction. Comes standard with Shock Pads and Improved Gas Vent 2, so sustained fire is a little easier on the wielder. A Smartgun variant is also available.

Standard model:

Type	Conceal	Ammo	Mode	Damage	Weight	Availability	Cost	Street Index
Shotgun	3	10 (m)	SA	10S	4	4/24hrs	1,500¥	2

Smartgun variant:

Type	Conceal	Ammo	Mode	Damage	Weight	Availability	Cost	Street Index
Shotgun	3	10 (m)	SA	10S	4	4/24hrs	2,200¥	2

(SWO note This one was in the SR1 "Blue Book", but did not make it to the SR2 rule book. These stats are converted from SR1 to SR2. We present it here so that those who don't have the original can at least have the Capture.)

[Are you sure? It wasn't in my SR1 book (5th printing)... —Gurth]

### Ranger Arms Security 12

This new weapon from Ranger Arms combines the firepower of a shotgun and that of fully-automatic rifle into a very lethal addition to any security team's arsenal. Features include: integral laser sight, folding stock, and gas vent 2.

Type	Conceal	Ammo	Mode	Damage	Weight	Availability	Cost	Street Index
Shotgun	3	15 (c)	SA/BF/FA	10S	4.5	10/8 days	2,000¥	2

>>>>[This thing HURTS! Ruined a damn good rigid breast plate! 'Course it looks real good on my wall too...'specially with all that blood on it. (His, not mine.) ]<<<<<

—Texan (02:42:52/06-12-54)

### Remington 1628

This shotgun is an ideal defensive firearm for anyone who needs reliable firepower. Its high capacity and firepower make it a threat for any assailant or intruder. The 1628 will accept the full range of ammunition and firearm accessories.

Type	Conceal	Ammo	Mode	Damage	Weight	Availability	Cost	Street Index
Shotgun	4	8 (m)	SS	8S	3	3/24hrs	500¥	1

>>>>[Vanilla, but reliable.]<<<<<  
 —Victor (06:12:31/03-12-54)

### Remington Rapid Assault 12

Another new entry into the world shotgun collection, except with a new twist. This new Remington wea-pon features the now standard features of modern assault shotguns with the addition of the Ares Smartchoke™. Standard features include burst fire, and smartgun link.

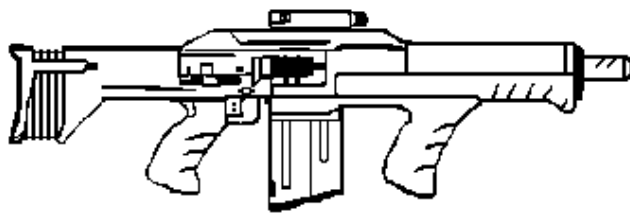

Type	Conceal	Ammo	Mode	Damage	Weight	Availability	Cost	Street Index
Shotgun	3	15 (c)	SA/BF	10S	4.5	12/8 days	2,000¥	2

>>>>["State-of-the-art bang-bang."]<<<<<  
 —Hardware (04:21:54/04-24-54)



## Multi-Weapon

### Mossberg M-712 Multi-Weapon System

Mossberg stunned the market this year with its M-712 MWS. This revolutionary new assault rifle combines the range and effectiveness of an assault rifle with the close-in support capability of a shotgun. However, Mossberg didn't stop there. To go with the shotgun, they developed mini-grenades for heavy firepower. Other features of this weapon are integral smartgun link, gas vent 2 (on the rifle), and mag 2 imaging scope.

Type	Conceal	Ammo	Mode	Damage	Weight	Availability	Cost	Street Index
Assault	N/A	35 (c)	SA/BF/FA	8M	6	12/7 days	4,000¥	3
Shotgun	—	15 (c)	SA	10S	—	—	—	—

>>>>[Jack of all trades, master of none ('cept cost) if you ask me.]<<<<<  
 —Hardware (12:02:43/01-02-54)

## Assault Rifles

### Kalishnikov AK-100

This is the second generation of the AK-97/98 series. It features a bullpup design accompanied by gas vent 2 and optional smartgun link. This is a very reliable design but it has recently been overshadowed by the more modern AK-101 just recently developed by Kalishnikov.

Standard model:

Type	Conceal	Ammo	Mode	Damage	Weight	Availability	Cost
------	---------	------	------	--------	--------	--------------	------

Assault N/A 30 (c) SA/BF/FA 8M 5.75 5/36hrs 1,000¥

Street Index

2

Smartgun model:

Type Conceal Ammo Mode Damage Weight Availability Cost

Assault N/A 30 (c) SA/BF/FA 8M 5.75 5/36hrs 2,000¥

Street Index

2



## Kalishnikov AK-101

The newest assault rifle in the Kalishnikov line. This rifle has been adopted as the new Russian army assault rifle. Featuring the now standard assault rifle round as well as gas vent 2, laser sight and optional smart-gun link, this rifle promises to be a significant improvement over the AK-97-98/100 series.

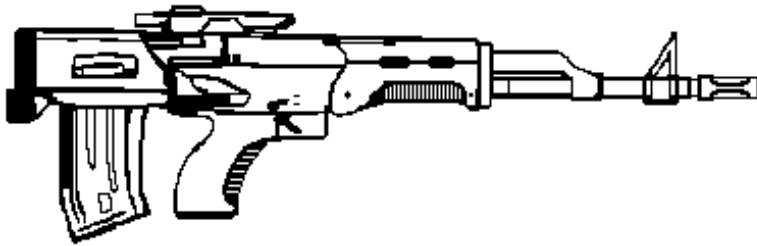
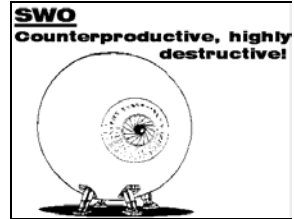

Type	Conceal	Ammo	Mode	Damage	Weight	Availability	Cost	Street Index
Assault	2	30 (m)	SA/BF/FA	8M	5.5	8/4 days	1,600¥	2

>>>>[The Pinko-Commies make a nice gun.]<<<<<  
 —Texan (23:48:27/6-24-54)

**FN-ARGL**

Not to be outdone by the increase in rifle/grenade systems present on the market today, Fabrique Nationale comes out with the FN-ARGL. This weapon follows the market trends for a light compact weapon system with heavy fire-power. This rifle features a mini-grenade launcher, laser sight, mag 2 imaging scope, and gas vent 2.

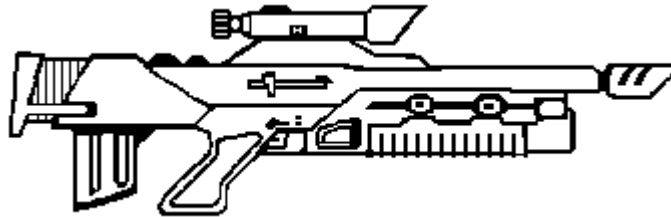

Type	Conceal	Ammo	Mode	Damage	Weight	Availability	Cost	Street Index
Assault	NYET	40 (c)	SA/BF/FA	8M	5	5/36hrs	2,000¥	2

>>>>[I can't get my hands around this one. Maybe they should try troll-sized handles.]<<<<<  
 —Blech (23:42:57/10-06-54)

>>>>[Trolls are so stupid!]<<<<<  
 —Iron Fist (00:43:21/10-07-54)

>>>>[Slow and painful, chummer. Slow and painful.]<<<<<  
 —Blech (20:21:02/10-07-54)

**Seco M-995**

The Israelis do it again with the Seco M-995. This state of the art assault system is excellent for government (army) or corporate strike team applications. This potent, compact assault weapon has many features, most of which are standard. These features include: mini-grenade launcher, rangefinder grenade link, gas vent recoil suppression (level 3), and integral laser sight or smartgun link.

**Standard model:**

Type	Conceal	Ammo	Mode	Damage	Weight	Availability	Cost	Street Index
Assault	N/A	30 (c)	SA/BF/FA	8M	5.75	10/4 days	3,000¥	3

**Smartgun variant:**

Type	Conceal	Ammo	Mode	Damage	Weight	Availability	Cost	Street Index
Assault	N/A	30 (c)	SA/BF/FA	8M	5.75	10/4 days	6,000¥	3

>>>>[Hee,hee,hee, look at all those toys. I want one!]<<<<<  
 —Slick (11:12:23/01-21-54)

>>>>[Yeah, it ALMOST has enough drek on it.]<<<<<  
 —Hardware (13:14:59/02-09-54)

## Grenade Launcher

### Ares Suppressor Automatic Grenade Launcher

Ares again breaks ground in the heavy weapons market. The Suppressor features burst fire capability for devastating firepower. This weapon has a standard integral laser sight, optional rangefinder grenade link, integral smartgun link, or smartlink/grenade link combo.

Standard model:

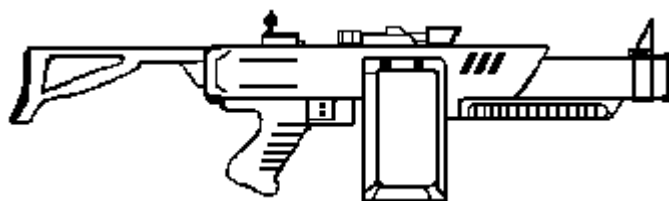

Type	Conceal	Ammo	Mode	Damage	Weight	Availability	Cost	Street Index
Grenade	N/A	12 (c)	SA/BF	grenade	7	18/14 days	3,400¥	3
<b>Rangefinder model:</b>								
Type	Conceal	Ammo	Mode	Damage	Weight	Availability	Cost	Street Index
Grenade	N/A	12 (c)	SA/BF	grenade	7	18/14 days	4,300¥	3
<b>Smartgun model:</b>								
Type	Conceal	Ammo	Mode	Damage	Weight	Availability	Cost	Street Index
Grenade	N/A	12 (c)	SA/BF	grenade	7	18/14 days	6,800¥	3
<b>Smartgun &amp; Rangefinder model:</b>								
Type	Conceal	Ammo	Mode	Damage	Weight	Availability	Cost	Street Index
Grenade	N/A	12 (c)	SA/BF	grenade	7	18/14 days	7,700¥	3

>>>>[BOOM! BOOM! BOOM! They're dead!]<<<<<  
 —Bad Karma (19:24:36/11-25-54)

## Light Machine Gun

### IWS Mini-5

Designed to compete with the Ares Vindicator minigun, this entry by IWS is a definite match. Its heavy firepower is accompanied by light weight, and laser sight or optional smartgun link. Integrated Weapon Systems: We Got The BIG Stuff.

Standard model:

Type	Conceal	Ammo	Mode	Damage	Weight	Availability	Cost	Street Index
LMG	NO	belt	FA	7S	14	24/14 days	13,000¥	2
	WAY		(minigun)					

Smartgun model:

Type	Conceal	Ammo	Mode	Damage	Weight	Availability	Cost	Street Index
LMG	NO	belt	FA	7S	14	24/14 days	26,000¥	2
	WAY		(minigun)					

>>>>[I think I'm beginning to like these IWS folks. The Mini-5 is a sight for sore eyes. The real advantage this beauty has is an improved ammo-feeding system which reduces the possibility of a jam during feeding. Believe me, this was a welcome sight after Mr. Vindicator shut up on me a couple months ago down south. I wonder if they take trade-ins?]<<<<<  
 —Bunker (03:10:16/10-04-54)

>>>>[Bunker, I thought I told you not to mention that job, EVER!]<<<<<<  
     —Prophet (18:44:26/10-05-54)  
 >>>>[What is it with Orks and BIG GUNS?]<<<<<<  
     —Iron Fist (12:31:06/11-01-54)  
 >>>>[I think its Freudian or something.]<<<<<<  
     —Prophet (04:45:12/11-05-54)  
 >>>>[?!?!?!?!]<<<<<<  
     —Bunker (05:12:22/11-06-54)



## Heavy Weapon

### IWS Assault 20

Made exclusively for military and corporate security units, this massive assault weapon claims one hundred percent takedown capability verses soft targets and excellent light armored vehicle destruction potential. Standard features are hip shock pads (rating 1) and improved gas vent 4. It will accept a full range of non-standard features. Integrated Weapon Systems: We Got The BIG Stuff.

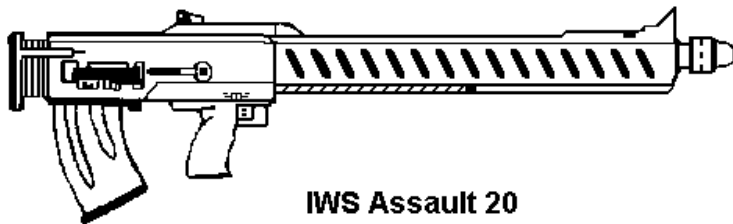

**IWS Assault 20**

Type	Conceal	Ammo	Mode	Damage	Weight	Availability	Cost	Street Index
Cannon	N/A	20 (m)	SA	18D	16	16/14 days	7,200¥	2

**Source note:** For those of you who are Appleseed fans, this is my representation of one of Briarios' guns.

>>>>[Lissen up, terms! This here beauty is 100% fun! They don't lie about it's capabilities; I got the chance to play with one a couple months ago and had a blast!]<<<<<<  
     —Bunker (02:43:12/8-29-54)  
 >>>>[Where the frag did \*you\* get hold of an IWS-20, Bunker?!]<<<<<<  
     —Zephyr (17:21:11/9-03-54)  
 >>>>[Chums, term, chums.]<<<<<<  
     —Bunker (22:36:42/9-05-54)

## Ammunition

### High Explosive Squash Head (HESH)

The special HESH rounds do not do any greater penetration, but they double knockdown penalties and they increase the wound by one category if they penetrate armor. In addition, armor is damaged 2 levels for every round that hits a target. Yes, these rounds are very effective. The HESH rounds have a legality of 3-L as per **Shadowtech**. These rounds are very nasty (my players found out through playtest). I would not suggest letting players get ahold of these in any quantity.

Conceal	Damage	Weight	Availability	Cost	Street Index
8	see above	.75	18/14 days	200¥	3

### Shotgun Mini-Grenade

These are mini-grenades designed to be fired from shotguns; they cannot be fired from standard grenade launchers, or from any other weapon that is not a shotgun. They were developed for the Mossberg M-712 Multi-Weapon System (page 42), but can be fired from any shotgun. Three different types exist: Concussion, Defensive, and Offensive. The stats below are for packs of ten.

**Concussion:**

Conceal	Damage	Power Level	Weight	Availability	Cost	Street Index
8	10M	-1 per meter	.2	7/4 days	600¥	3

**Defensive:**

Conceal	Damage	Power Level	Weight	Availability	Cost	Street Index
8	8S	-1 per .5 meter	.2	6/4 days	600¥	3

**Offensive:**

Conceal	Damage	Power Level	Weight	Availability	Cost	Street Index
8	8S	-1 per meter	.2	6/4 days	600¥	3

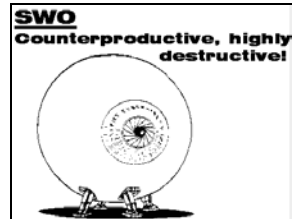

>>>>[The weapons, gear, cyberware, and vehicles from R. Talsiorian's Cyberpunk 2020 are very suitable for use in Shadowrun. For this reason, many of them are reproduced below, with Shadowrun stats. The names and other things have been left intact to give the designers their due credits. Some weapons are noted as firing Firepower™ ammo (see page 27); these weapons' Damage Codes have *not yet been adjusted for this ammo!* In other words, use the listed Damage Code for Regular ammo, and add +1 to the Power when firing Firepower™ rounds.]<<<<<  
 —Gurth (BA:09:87/65-43-21)



## Armor

### Heavy Leather (Jacket or Pants)

Good for road rash, stopping knives, etc. A good slug will rip you to bits, however.

Conceal	Ballistic	Impact	Weight	Availability	Cost	Street Index
—	0	2	1	always	750¥	.75

>>>>[Leather sucks.]<<<<<  
 —Latex Louis (14:21:46/05-10-55)

### Kevlar T-Shirt/Vest

Can be worn unnoticeably under most street clothes.

Conceal	Ballistic	Impact	Weight	Availability	Cost	Street Index
11	2	0	1	4/48hrs	220¥	2

>>>>[These things look just like ordinary T-shirts. You have to look real hard to notice the difference.]<<<<<  
 —Jane Doe (14:53:25/05-12-55)

### Kevlar Armor Jacket

Personal protection for the fashion conscious, these lightweight Kevlar jackets have nylon coverings that resemble normal jackets.

	Conceal	Ballistic	Impact	Weight	Availability	Cost	Street Index
Light	8	3	2	1	2/36hrs	600¥	.8
Medium	6	4	3	1.5	3/36hrs	800¥	.8
Heavy	5	5	4	2	3/36hrs	1,000¥	.8

>>>>[These things have been around for ages, and I've definitely seen less-obvious armors.]<<<<<  
 —Washer (04:02:47/05-08-55)



**Helmet**

Heavy duty protection for the head, standard for most military. Some are made of steel, others of kevlar and high impact plastics. Most (90%) have face shields. The Armor Ratings of a helmet are added to other armor.

	Conceal	Ballistic	Impact	Weight	Availability	Cost	Street Index
Nylon	—	+1	+1	—	12/14 days	200¥	1.5
Steel	—	+1	+2	—	14/14 days	250¥	1.75

**Flack Vest**

Standard protection for combat soldiers, the flack vest is designed to stop small arms fire, grenade shrapnel, but only slows up assault rifle rounds.

Conceal	Ballistic	Impact	Weight	Availability	Cost	Street Index
—	4	4	2	6/4 days	1,000¥	1

>>>>[The word is "flak."]<<<<<  
—Cobrette (16:28:17/05-12-55)

**Doorgunner's Vest**

Heavy duty protection for stationary positions, like machinegun nests, helicopter doors, etc.

Conceal	Ballistic	Impact	Weight	Availability	Cost	Street Index
—	6	4	12	9/8 days	7,500¥	1.9

**MetalGear™**

Laminated expoxide plate armor. Bulky, and designed in modular sections, with helmet, arm and leg coverings, torso and back clamshell. Treat this as Hardened armor, and add the Armor Ratings of all individual components together when more than one item is worn.

	Conceal	Ballistic	Impact	Weight	Availability	Cost	Street Index
Arm*	2	1.5	1.25	2	10/7 days	2,000¥	3
Helmet	—	1	1	1.5	10/7 days	2,000¥	3
Leg*	2	1.5	1.25	3	10/7 days	2,000¥	3
Torso	3	2	1.5	4	10/7 days	2,000¥	3

\* = for two arms and legs: wearing two sets of arm armor will *not* give armor 3/2.5



## Communications

### Mastoid Commo

All commos are radio transceivers. This one is glued to the jaw and temple. You send via subvocalization and receive with soundless vibrations. Range 15 kilometers.

Conceal	Rating	Weight	Availability	Cost	Street Index
8*	—	—	2/12hrs	1,000¥	.6

\* = concealability drops to 3 when the commo is worn

### Pocket Commo

A typical small walkie-talkie. Range 15 kilometers.

Conceal	Rating	Weight	Availability	Cost	Street Index
7	—	.1	always	500¥	.5



## Vehicles

### Bell Boeing V-22B Osprey

The Osprey mounts two large, wide propped engine nacelles at the ends of long, high-lift wings. The engines can be tilted from a forward facing direction to a vertical position, allowing the aircraft to take off and hover vertically. The wings can be folded back along the body for better storage (takes 1 minute to fold back, and 5 minutes to deploy before flight), making the Osprey a perfect vehicle to work from rooftop airpads and unprepared airstrips.

Ospreys can be found as commuter vehicles between city centres and hub airports, or as corporate aircraft operating from rooftop pads atop headquarters skyscrapers.

	Handling	Speed	B/A	Sig	Apilot	Cost
Osprey	5	170/510	4/0	3	3	900,000¥
<b>Seating:</b> Twin bucket seats		<b>Access:</b> 1 + 1 standard + 1 double-sized				
<b>Economy:</b> 2 km per liter*		<b>Fuel:</b> IC/450 liters				
<b>Cargo/Storage:</b> 10 CF storage + 45 CF cargo						
<b>Landing/Take-off Profile:</b> VTOL/VTOL						
<b>Options:</b> The Commuter variant has 40 bucket seats in a 2-aisle-2 layout. The Executive variant has ten individual bucket seats. The Cargo variant has ten folding benches and 10(+40)CF cargo, 10(+50) if seats are removed.						
* = VTOL economy .5km/liter						

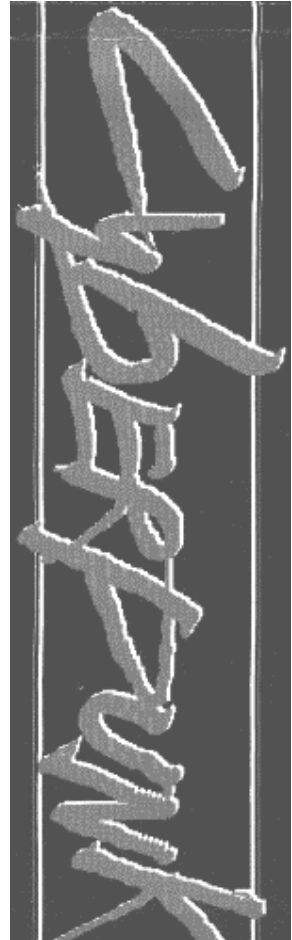

### Bell F-152 Aerogyro

The riots of the late 90's required new tactics for operating in urban areas. Chief among these was the introduction of light, one man helicopters or aerogyros. The F-152 is currently used by police units, corporate defense teams, merc assault operations teams, and BTL-running gangs. An unarmed version, known as the Bell-15, is a popular recreational vehicle.

	Handling	Speed	B/A	Sig	Apilot	Cost
Bell 15 / F-152	4	160/480	2/0	4	1	300,000¥
<b>Seating:</b> Single bucket seat		<b>Access:</b> Full canopy				
<b>Economy:</b> 2 km per liter		<b>Fuel:</b> MultiF/40 liters				
<b>Storage:</b> 1 CF underseat						
<b>Landing/Take-off Profile:</b> VTOL/STOL						
<b>Options:</b> The F-152 has one Firmpoint, firing forward, and Security I (4) sensors.						

>>>>[One shot with a catapult and they do down.]<<<<<  
 —Dexter (13:26:16/05-09-55)

**Honda Metrocar**

Common type of city car, powered by a multifuel engine.

Metrocar	<b>Handling</b> 4/10	<b>Speed</b> 20/60	<b>B/A</b> 1/0	<b>Sig</b> 5	<b>Apilot</b> 0	<b>Cost</b> 7,000¥
<b>Seating:</b> Single bench		<b>Access:</b> Full canopy				
<b>Economy:</b> 100 km per liter		<b>Fuel:</b> MultiF/10 liters				
<b>Storage:</b> 2 CF underseat						

>>>>[I take it nobody here wants to be seen in one of these?]<<<<<  
 —Rockhead (08:47:11/05-06-55)

**McDonnell-Douglas AV-4 Tactical Urban Assault Vehicle**

The AV-4 Tac Vehicle was developed as a light assault aircraft capable of operation in close urban areas where rotary and tilting aircraft cannot penetrate. Short, bulbous, and equipped with only rudimentary maneuver wings, the AV-4 has the aerodynamic characteristics of a rock, relying on brute force of its huge jet engine to keep it aloft.

The AV-4 is used by police or corporate troops for urban assaults (using the two belly-mounted firmpoints to mount machine gun pods). They are also used as emergency vehicles —specifically by the Trauma Team organizations— or as corporate vehicles for special deliveries and meetings.

The AV-4 is a Vectored Thrust vehicle.

AV-4	<b>Handling</b> 5	<b>Speed</b> 150/450	<b>B/A</b> 5/6	<b>Sig</b> 3	<b>Apilot</b> 2	<b>Cost</b> 1.5M¥
<b>Seating:</b> Twin bucket seats		<b>Access:</b> 2 + 2 standard + 1 double-sized				
<b>Economy:</b> .75 km per liter		<b>Fuel:</b> IC/800 liters				
<b>Cargo:</b> 75 CF cargo						
<b>Landing/Take-off Profile:</b> VTOL/STOL						
<b>Options:</b> Military and security models come with two forward-firing firmpoints. All models can be outfitted with any seating arrangement desired.						

**AV-6 Combat Assault Vehicle**

This is a high-speed, fully combat capable version of the AV-4 aerodyne, with fans mounted in heavily armored side housings. The AV-6 mounts a single chin-mounted remote micro-turret, plus two forward-firing hardpoints. AV6's are primarily used by military units.

AV-6	<b>Handling</b> 5	<b>Speed</b> 210/630	<b>B/A</b> 6/9	<b>Sig</b> 3	<b>Apilot</b> 3	<b>Cost</b> 3.5M¥
<b>Seating:</b> Twin bucket seats		<b>Access:</b> 2 + 2 standard + 1 double-sized				
<b>Economy:</b> .5 km per liter		<b>Fuel:</b> IC/1,950 liters				
<b>Cargo:</b> 50 CF cargo						
<b>Landing/Take-off Profile:</b> VTOL/STOL						
<b>Options:</b> Any interior seating arrangement is possible. Comes with complete rigger control gear.						



### Toyo-Chrysler Omega

A typical medium sedan.

	<b>Handling</b>	<b>Speed</b>	<b>B/A</b>	<b>Sig</b>	<b>Apilot</b>	<b>Cost</b>
Omega	4/8	50/150	2/0	2	1	20,000¥
<b>Seating:</b> Twin bucket seats + bench			<b>Access:</b> 4 standard			
<b>Economy:</b> 50 km per liter			<b>Fuel:</b> MultiF/35 liters			
<b>/Storage:</b> 5 CF trunk						

### Toyota Avante

Exotic sportscar, combining cyberinterface technology with a high powered multifuel engine. Comes with Datajack Link already installed.

	<b>Handling</b>	<b>Speed</b>	<b>B/A</b>	<b>Sig</b>	<b>Apilot</b>	<b>Cost</b>
Avante	3/8	95/285	2/1	1	3	480,000¥
<b>Seating:</b> Twin bucket seats			<b>Access:</b> 2 standard			
<b>Economy:</b> 35 km per liter			<b>Fuel:</b> MultiF/125 liters			
<b>Cargo/Storage:</b> 2 CF underseat + 3 CF trunk						

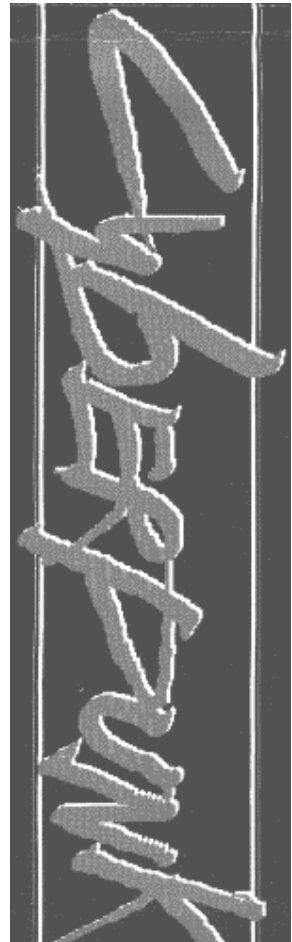

## Weapons

### Melee Weapons

#### Kendachi Monokatana®

Sword length version of monoblade. Resembles a hightech katana with a milky, nearly transparent blade.

<b>Conceal</b>	<b>Reach</b>	<b>Damage</b>	<b>Weight</b>	<b>Availability</b>	<b>Cost</b>	<b>Street Index</b>
3	1	(str+4)M	1	8/5 days	1,200¥	2.5

#### Kendachi Monoknife®

Mono-sectional crystal blade. Incredibly sharp. In the Japanese "tanto" style. Also available in a naginata form.

<b>Knife:</b>						
<b>Conceal</b>	<b>Reach</b>	<b>Damage</b>	<b>Weight</b>	<b>Availability</b>	<b>Cost</b>	<b>Street Index</b>
7	—	(str+1)L	.5	6/60hrs	200¥	1
<b>Naginata:</b>						
<b>Conceal</b>	<b>Reach</b>	<b>Damage</b>	<b>Weight</b>	<b>Availability</b>	<b>Cost</b>	<b>Street Index</b>
5	—	(str+2)L	.5	6/60hrs	300¥	1

### Projectile Weapons

#### EagleTech "Stryker" Crossbow

Plastic and bimetal crossbow. Silent, deadly, and you usually get your ammo back.

<b>Type</b>	<b>Conceal</b>	<b>Str. Min.</b>	<b>Damage</b>	<b>Weight</b>	<b>Availability</b>	<b>Cost</b>	<b>Street Index</b>
Medium Crossbow	2	3	6M	3.25	6/48hrs	440¥	1

**EagleTech "Tomcat" Compound Bow**

Gyrobalanced, stabilized compound bow. Silent & deadly.

Type	Conceal	Str. Min.	Damage	Weight
Bow	2	2+	(Str.Min+4)M	1.5
Availability	Cost	Street Index		
6/48hrs	(150x Str.Min)¥	1		

>>>>[What do they think we are? Savages?]<<<<<  
 —Rydergirl (04:37:52/05-03-55)



**Hold-Out Pistols**

**BudgetArms C-13**

A light duty autopistol used as a hold-out and a "lady's gun".

Type	Conceal	Ammo	Mode	Damage	Weight	Availability	Cost	Street Index
Hold-Out	8	8 (c)	SA	4L	.5	2/8hrs	150¥	.75

>>>>["Lady's gun" ??? I wouldn't be seen dead with one of these.]<<<<<  
 —Tessa (17:31:53/05-13-55)

>>>>[You'd soon be dead if you'd try to use one, though. Worthless piece of trash if ever I saw one.]<<<<<  
 —Jellyfish (02:41:55/05-14-55)

**Dai Lung Cybermag 15**

Cheap Hong Kong knockoff, often used by gangers and other street trash.

Type	Conceal	Ammo	Mode	Damage	Weight	Availability	Cost	Street Index
Hold-Out	7	10 (c)	SA	4L	.5	3/12hrs	100¥	.7

>>>>[The only plus this gun has is its large clip, compared to others of its kind.]<<<<<  
 —Tessa (17:34:20/05-13-55)

**Federated Arms X-22**

The ubiquitous "Polymer-one-shot" cheap plastic pistol. Available in designer colors.

Type	Conceal	Ammo	Mode	Damage	Weight	Availability	Cost	Street Index
Hold-Out	7	10 (c)	SA	4L	.5	2/12hrs	300¥	.8

>>>>[Take my advice: don't even accept these kinds of guns even if your wife gives 'em to you for your birthday.]<<<<<  
 —Rellik (15:21:06/05-04-55)



**Light Pistols**

**Dai Lung Streetmaster**

Another Dai Lung cheapie, built for the Street.

Type	Conceal	Ammo	Mode	Damage	Weight	Availability	Cost	Street Index

Light      6      12 (c)      SA      6L      1      3/12hrs      325¥      .8

>>>>[Nobody except for the lowest gutter punks carry this toy.]<<<<<  
 —Me Again (03:11:27/05-07-55)

**Federated Arms X-9mm**

A sturdy Street Samurai's gun, used as a standard military sidearm in the C.F.S. and E.C.C.

Type	Conceal	Ammo	Mode	Damage	Weight	Availability	Cost	Street Index
Light	5	12 (c)	SA	6L	1	3/12hrs	450¥	.75

>>>>[Who are they trying to fool? No real samurai gets a gun of this quality or firepower.]<<<<<  
 —Findler-Man (08:51:33/05-12-55)

**Militech Arms Avenger**

A well-made autopistol with good range and accuracy. A professional's gun.

Type	Conceal	Ammo	Mode	Damage	Weight	Availability	Cost	Street Index
Light	6	10 (c)	SA	6L	1	3/12hrs	325¥	.8

>>>>[If Militech'd chamber it for better ammo, this gun has the potential of becoming a real professional's gun. For the moment, dream on, Militech.]<<<<<  
 —Wager (13:44:08/05-13-55)

**Heavy Pistols**

**Armalite 44**

Designed as an alternative to the 2048 UCAS Army sidearm trials. A solid contender. Comes equipped to fire Firepower™ ammunition as standard.

Type	Conceal	Ammo	Mode	Damage	Weight	Availability
Heavy	4	8 (c)	SA	9M	2.25	4/24hrs
<b>Cost</b>	<b>Street Index</b>					
450¥	1					

>>>>[Shame about the clip's capacity. Otherwise, it's a good gun, especially with the Firepower™ it provides.]<<<<<  
 —Wager (13:46:11/05-13-55)

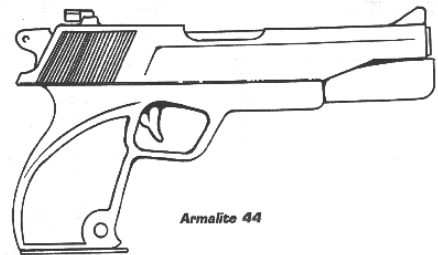

Armalite 44

**BudgetArms Auto 3**

It's cheap. It's powerful. It blows up sometimes. What else do you want?

Type	Conceal	Ammo	Mode	Damage	Weight	Availability	Cost	Street Index
Heavy	5	8 (c)	SA	9M	2.25	4/12hrs	350¥	.7

>>>>[I want a gun that doesn't blow up.]<<<<<  
 —Cultist (03:14:30/05-08-55)

**Colt AMT Model 2000**

Now the standard officer's sidearm for the Sioux Army, the M-2000 served well in the Central Americal Wars. It fires Firepower™ ammo as standard.

Type	Conceal	Ammo	Mode	Damage	Weight	Availability	Cost	Street Index
Heavy	5	8 (c)	SA	9M	2.5	5/24hrs	500¥	1

>>>>[For some reason all these guns have too little ammo to last any kind of firefight. Just eight rounds, most of them!]<<<<<  
 —Weasel (19:41:50/05-03-55)

>>>>[And no standard extras of any kind.]<<<<<  
 —E.T. (10:58:15/05-05-55)

>>>>[If it's standard it's not an extra.]<<<<<  
 —Gurth (\*\*:\*\*\*/##-##-##)

**SternMeyer Type 35**

Rugged, reliable, with fine stopping power. Another fine E.C.C. product from Germany.

Type	Conceal	Ammo	Mode	Damage	Weight	Availability	Cost	Street Index
Heavy	5	8 (c)	SA	9M	2.5	4/36hrs	400¥	1

**Tasers**

**Miltech Electronics Taser**

Zap. About the size of a small hand flashlight. Use the **Shock Weapons Rules**, p.103, **SR11**.

Type	Concealability	Ammo	Mode	Damage	Weight
Taser	6	10 (m)	SS	8S Stun + Shock	1.5
Availability	Cost	Street Index			
5/36hrs	600¥	1.4			



## Submachine Guns

### Arasaka Minami 10

The standard Arasaka Security weapon, found worldwide. A good, all round weapon.

Type	Conceal	Ammo	Mode	Damage	Weight	Availability	Cost
SMG	6	40 (c)	SA/BF/FA	7M	3.25	3/24hrs	1,000¥
<b>Street Index</b>							
.9							

>>>>[They're right about this one: you can pick up a whole lot worse from your neighborhood fixer. Too bad it doesn't come with accessories, though.]<<<<<  
 —Carina (09:17:24/05-10-55)

### Federated Arms Tech Assault II

An updated version of the venerable Tech Assault I, features larger clip, better autofire, no melting. Honest.

Type	Conceal	Ammo	Mode	Damage	Weight	Availability	Cost
SMG*	5	50 (c)	SA/FA	6L	2.5	4/36hrs	600¥
<b>Street Index</b>							
1							
* = fires LP ammo							

>>>>[No melting? What the frag is that supposed to imply?]<<<<<  
 —Virtuoso (16:59:01/05-07-55)

>>>>[The plastic casing of the original Tech Assault (you can find it in some issue of a magazine called Solo of Fortune) had a tendency to melt if you used it on autofire. Ever since I had one melt in my hands, I steer well clear of anything with the name Federated Arms stamped into it. Buy Ares or some other drek, anything but FA.]<<<<<  
 —Hairy Harry (03:21:39/05-10-55)

### H&K MP-2013

Heckler & Koch's updating of the MP-5 classic, with compound plastics and built-in sound suppressor.

Type	Conceal	Ammo	Mode	Damage	Weight
SMG	4	35 (c)	SA/BF/FA	6M	2.75
<b>Availability</b>	<b>Cost</b>	<b>Street Index</b>			
5/48hrs	900¥	1.1			

>>>>[&@>KD+  
 K\$98rff\$@)\_==]<<<<<  
 — (:::/---)  
 >>>>[&&&!#(\$KHHHTY??\_--2]<<<<<  
 — (:::/---)  
 >>>>[Huh? What happened here?]<<<<<  
 —Animal (06:29:18/05-13-55)

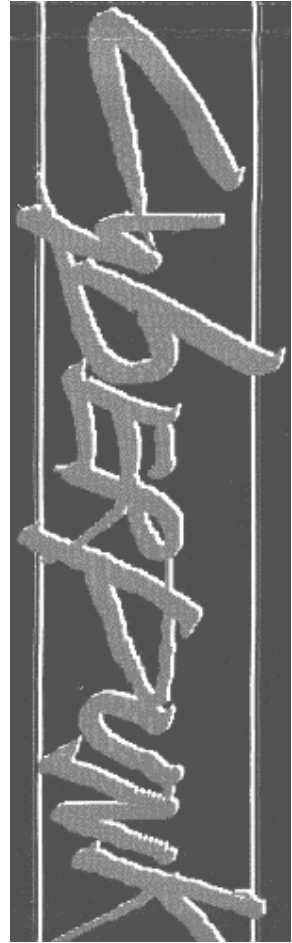
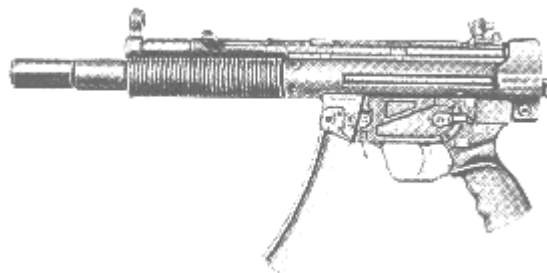

>>>>[Some folks said something about the MP-2013, it being an old and worthless piece of trash or something. Next thing we know, a decker crashes into the datastore and chops out those comments from the file with the nastiest Attack program I've yet seen. No restoring possible, I'm afraid.]<<<<<

—Sysop (12:27:51/05-13-55)

>>>>[Is it possible that H&K doesn't like negative publicity?]<<<<<

—Freddy (14:21:58/05-13-55)

>>>>[The decker had "corp" written all over him/her, but if (s)he was H&K I don't know.]<<<<<

—Sysop (14:23:28/05-13-55)

>>>>[Just take a look at the fragging name: "MP-2013!" Not exactly a new weapon, is it?]<<<<<

—Lori (13:48:29/05-14-55)



**H&K MPK9**

A light composite submachinegun with integral sights. Used by many European street samurai.

Type	Conceal	Ammo	Mode	Damage
SMG	5	35 (c)	SA/BF	7M
Weight	Availability	Cost	Street Index	
3	5/36hrs	1,040¥	.8	

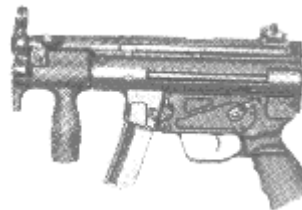

>>>>[Like, should we give a frag about European samurai?]<<<<<

—Redskin (05:47:28/05-12-55)

**H&K MPK-11**

Possible the most used Samurai's gun in existence, the MPK-11 can be modified into four different designs, including a bullpup configuration, standard SMG, assault carbine, and a grenade launcher mount. Grenade launcher not included.

Type	Conceal	Ammo	Mode	Damage	Weight	Availability	Cost	Street Index
SMG	4	30 (c)	SA/FA	7M	3.5	5/48hrs	1,400¥	1.2

>>>>[If you're to believe everything you read in these kinds of guides, every fragging gun ever made is the "most used" or "voted best of '55" or some other drek.]<<<<<

—Willy Wonka (20:21:49/05-12-55)

**Ingram MAC-14**

Updated MAC-10, with composite body and cylindrical feeding magazine.

Type	Conceal	Ammo	Mode	Damage	Weight	Availability	Cost	Street Index
SMG	6	20 (c)	SA/FA	7M	3	4/36hrs	650¥	1

>>>>[ Check out the MAC-20 on page 14.]<<<<<

—Gurth (61:84:05/GE-TY-OU)

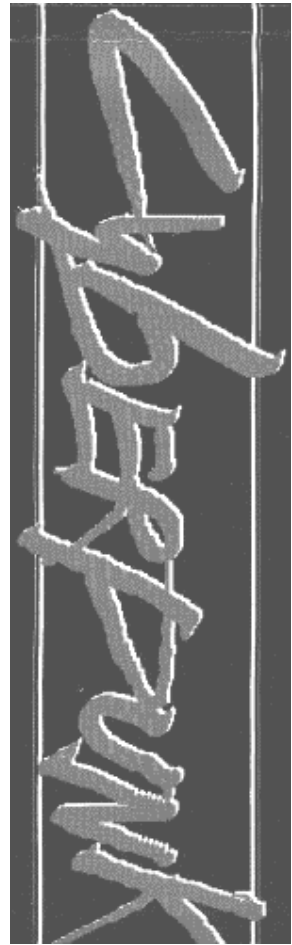

**Sternmeyer SMG 21**

Sternmeyer's best entry in the anti-terrorist category, with wide use on SWAT teams. Has a folding stock.

Type	Conceal	Ammo	Mode	Damage	Weight	Availability	Cost
SMG	4	30 (c)	SA/BF/FA	7M	3.25	4/36hrs	1,000¥
Street Index	1.1						



**Uzi Miniauto 9**

Uzi's entry into the second half of the 21st century, all plastic, with a rotary electric clip and adjustable trigger. The choice for many street samurai.

Type	Conceal	Ammo	Mode	Damage	Weight	Availability	Cost
SMG	5	30 (c)	BF/FA	6M	3	4/36hrs	700¥
Street Index	1						

>>>>[The Uzi is over-rated.]<<<<<  
 —Girl (14:52:48/05-03-55)



**Shotguns**

**Arasaka Rapid Assault Shot 12**

A high-powered auto shotgun with lethal firepower. Used by Arasaka



worldwide. Another good reason to avoid the Boys in Black.

Type	Conceal	Ammo	Mode	Damage	Weight	Availability	Cost	Street Index
Shotgun	1	20 (c)	SA/FA	8S	5.5	8/10 days	1,800¥	2.25

>>>>[Now *this* is firepower. I use it to hose down corridors or alleys.]<<<<<  
 —Stacey (14:32:05/05-11-55)

**Sternmeyer Stakeout 10**

Light duty stakeout shotgun, used by city police departments.

Type	Conceal	Ammo	Mode	Damage	Weight	Availability	Cost	Street Index
Shotgun	4	10 (m)	SA	9S	3.75	8/7 days	900¥	1.5

## Assault Rifles

### AKR-20 Medium Assault

A plastic and carbon fibre update of the AKM, distributed throughout the remains of the Russian Bloc. It has a top-mounted Laser Sight, and a barrel-mounted Gas Vent, rating 1.

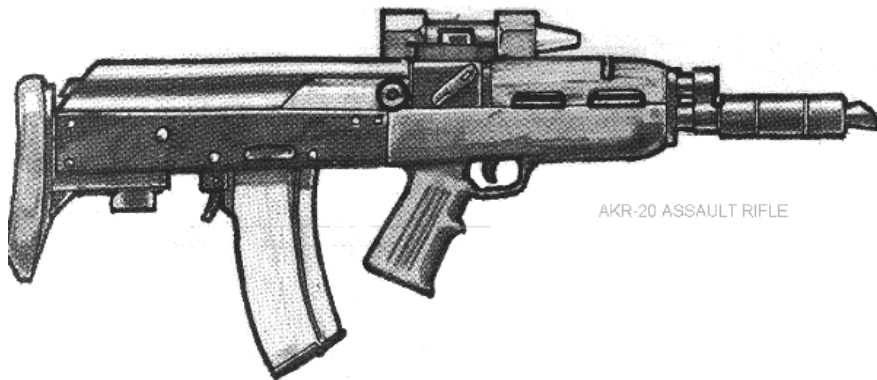

AKR-20 ASSAULT RIFLE

Type	Conceal	Ammo	Mode	Damage	Weight	Availability	Cost
Assault	3	30 (c)	SA/BF/FA	8M	4	5/48hrs	1,000¥
<b>Street Index</b>							
2							

>>>>[How many AK-variants can they come up with?]<<<<<  
 —Slime (16:02:12/05-14-55)

>>>>[Plenty.]<<<<<<  
 —Lalala (05:01:47/05-17-55)

### FN-RAL Heavy Assault Rifle



The standard NATO assault weapon for battlefield work. Bullpup design, collapsing stock. Comes with Magnification 1 Imaging Scope (top mount).

Type	Conceal	Ammo	Mode	Damage	Weight	Availability	Cost	Street Index
Assault	3	30 (c)	SA/FA	8M	5	5/60hrs	1,200¥	2

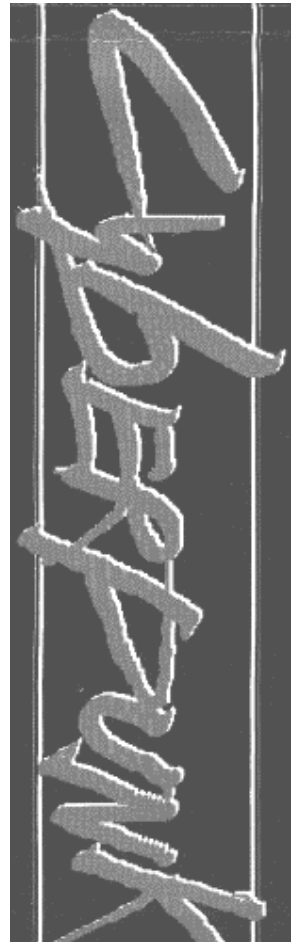

### Kalashnikov A-80 Heavy Assault Rifle

Another Russian retread, with improved sighting and lightened with composites.

Type	Conceal	Ammo	Mode	Damage	Weight	Availability	Cost	Street Index
Assault	1	35 (c)	SA/FA	8M	4.5	4/36hrs	1,100¥	2.5

>>>>[God, still more AK-variants!! Is it in fashion this year to wave an AK around? (I should get one, in that case)]<<<<<  
 —JJ (13:02:51/05-08-55)

>>>>[The reason for there being so many AK-variants is simple: its cheaper to base your "new" weapon on an existing one than to design a totally new one. Especially if you base your weapon on a well-proven (and good) design like the AK-series. Julie, you'd be surprised how many weapons are based on the AK without being obvious clones.]<<<<<  
 —Gurth (this space for rent)

>>>>[OK, I'll bite: name me a couple.]<<<<<  
 —JJ (04:42:20/05-11-55)

>>>>[Well, it all started with the AK-47 (as Coyote pointed out). Then came the AKM, AK-74, AK-97, AK-98, AK-100, AK-101, and loads of others that look like the original AK. But take a 20th century Finnish Valmet M60, M62, or M76 and you'll find that those have an AK-mechanism. The Israeli Galil (late 20th century) is based on the M76, so it's also an AK-variant. Then we have the little-known Ares Mark One from 2034, and... need I go on?]<<<<<  
 —Gurth (CNNE:SPNA:BCTNT/but-mostly-BS)

### Militech Ronin Light Assault

A light, all purpose update, similar to the M-16B. Has a Laser Sight on the top mount.

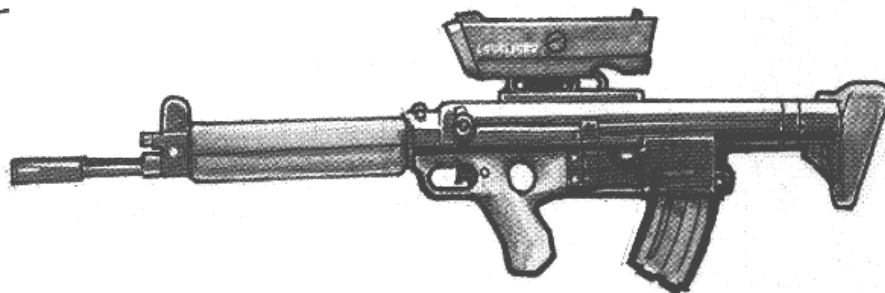

Type	Conceal	Ammo	Mode	Damage	Weight	Availability	Cost	Street Index
Assault	1	35 (c)	SA/BF/FA	8M	3.5	4/48hrs	900¥	2

>>>>[Quality, like you'd expect from Militech.]<<<<<  
 —Jackknife (08:41:34/05-06-55)

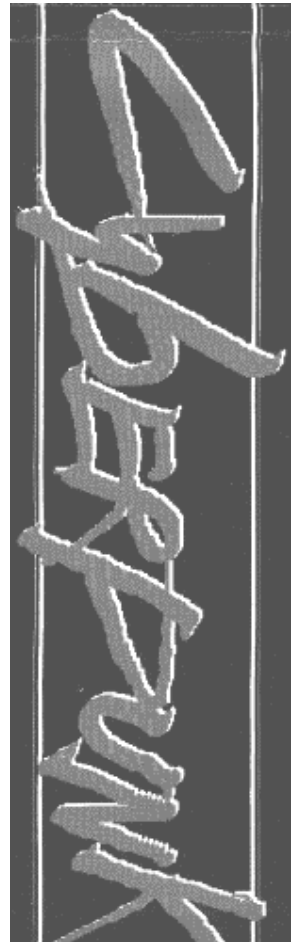

## Grenade Launcher

### Grenade Launchers

Launcher may be attached (under barrel) to any assault rifle, or hand-held.

Type	Conceal	Ammo	Mode	Damage	Weight	Availability	Cost
Grenade	(-2)	1 (m)	SS	grenade	1	6/4 days	1,250¥
<b>Street Index</b>							
2.75							

>>>>[You're a lot better of buying a multi-shot launcher. This thing is old-fashioned.]<<<<<  
 —Chat (02:31:44/05-10-55)

## Heavy Weapons

### Barrett-Arasaka Light 20mm

The cyberpsycho hunter's favorite. Almost 2 meters long, this "cannon" fires a depleted uranium shell at supersonic speeds.

Type	Conceal	Ammo	Mode	Damage	Weight	Availability	Cost
Cannon	—	10 (c)	SS	18D	19	15/14 days	6,000¥
<b>Street Index</b>							
2							

### Scorpion 16 Missile Launcher

The third generation of the Stinger missile launcher, this shoulder arm fires one missile.

Type	Conceal	Ammo	Mode	Damage	Weight	Availability	Cost
Missile	—	1 (b)	SS	missile	5	10/14 days	6,000¥
<b>Street Index</b>							
2							

### Militech Rocket-Grenade Launcher

Shoulder-mounted, rocket-powered grenade launcher. Heavily used in the Central American conflicts under the name *RPG-A*.

Type	Conceal	Ammo	Mode	Damage	Weight	Availability	Cost	Street Index
Missile	—	1 (m)	SS	missile	4.5	9/14 days	4,500¥	2.5



# NEW from Kohu North America, Inc.!

## SHAPED EXPLOSIVES

This new-for-'54 range of explosives and detonators was designed with stealth in mind. Place them anywhere, inconspicuous because of their common shapes, sizes and weights. They look like normal, everyday objects...until you let them explode!



### Detonators

A line of all-new detonators, which can be used with every modern explosive, military or commercial. These detonators are both reliable and simple to operate, and are inexpensive as well. KNA brings you the best!

KNA detonators come in three sizes (micro, mini, and normal) and a large number of different types. Micro detonators are small disks, some 5mm in diameter, and average 3mm thick, that are pressed into the explosive charge. Their weight is negligible, and concealability is infinite.

Mini detonators are pin-shaped, some 8mm in diameter and 4cm long. These are also pressed into the explosive. Weight is 20 grams, concealability is 15.

Normal detonators are square, 1cm thick, and with sides of 6cm. These have two small spikes at the back, which are pressed into the explosive. Weight is 100 grams, and concealability is 9.

All detonators use absolutely no metal components, making them undetectable to metal detectors. All internal systems are either fibre-optics or electrically conducting polymers, while the outer casing is made of hard impact plastic. All are available in 8 designer colors: white, black, blue, bright green, dark green, yellow, red, or orange.

>>>>[Christ! Detonators in designer colors?! What next? Explosives that explode in designer colors with the latest dance tunes as background sounds?!]<<<<<  
—Plastique (16:16:28/30-JAN-54)

As for different types of detonator, the following are available:

### Radio Detonator

Once this picks up the pre-programmed radio signal (selected by the user), it sets off the explosives. The maximum range from which it can be detonated depends on the remote control unit, not on the detonator itself. Available in micro, mini, and normal types.

	Availability	Cost	Street Index
Micro	6/48hrs	500¥	4
Mini	5/48hrs	300¥	3
Normal	4/48hrs	200¥	2

### Timer Detonator

These can be programmed for detonation at any time between 0 seconds and 24 hours, adjustable in steps of 1 second. Available in micro, mini, and normal sizes.

	Availability	Cost	Street Index
Micro	6/48hrs	300¥	3.5
Mini	5/48hrs	150¥	2.5
Normal	4/48hrs	75¥	1.9

## Laser Detonator

This detonator comes in two parts: one is the actual detonator, one is the laser remote-control unit. The detonator/receiver can be set in either of two modes: in mode 1, it detonates when it receives a pulse from the laser; in mode 2, it detonates when it does *not* receive a laser pulse. Mode 1 can thus be used for remote-detonation of the explosives, while mode 2 effectively makes a "booby-trap."

Setting up the laser requires a Complex Action and a Firearms skill test (to aim the laser correctly). Ranges are short 1-5m, medium 6-15m, long 16-25m, extreme 25-50m. If the laser is further away than 50 meters, it does not have sufficient power to detonate the explosives. Additional tests may be made on the user's next action if the first fails.

Available only in normal size. The laser unit is comparable to a laser sight, and is not powerful enough to inflict damage. It has a concealability of 5. The laser unit is reusable, and can be used 10 times for every six-hour recharge.

	Availability	Cost	Street Index
Normal	8/70hrs	350¥	3.5
Laser unit	6/48hrs	700¥	1.1

## Pressure Detonator

This detonator explodes when pressure is exerted on its top: a weight of around five kilograms is enough to detonate. Available in mini and normal sizes.

	Availability	Cost	Street Index
Mini	4/48hrs	100¥	1.5
Normal	3/48hrs	75¥	1.25

## Pull Detonator

The opposite of the pressure detonator, this explodes when the ring on its top is pulled out. A wire can be tied to the ring to make this an effective trap. Available in mini and normal sizes.

	Availability	Cost	Street Index
Mini	4/48hrs	100¥	1.5
Normal	3/48hrs	75¥	1.25

## Electric Detonator

This detonator responds to an electric signal: the current of a 1.5 volt watch battery is enough to detonate the explosives, though larger currents can also be used. Available in all sizes.

	Availability	Cost	Street Index
Micro	8/60hrs	425¥	3
Mini	6/48hrs	275¥	3
Normal	4/48hrs	150¥	2

## Sound Detonator

Featuring a built-in microphone and analytical computer, the sound detonator can be set to explode when it receives a specific sound frequency, or when the sound volume exceeds a specific number of decibels. Only available in normal size.

	Availability	Cost	Street Index
Normal	5/36hrs	400¥	2.5



## Light Detonator

Perfect for application in modern fibre-optic controlled devices, this detonator sets off when it receives a light pulse through the attached fibre-optic. The frequency it is to respond to can be set by the user. Available in all sizes.

	Availability	Cost	Street Index
Micro	10/72hrs	750¥	3.5
Mini	8/60hrs	500¥	3.25
Normal	6/48hrs	350¥	3.15

>>>>[One big ommision in this list, I feel, is a combination-detonator: two or more of the above combined into one.]<<<<<

—Jacqueline (02:45:18/01-18-54)

>>>>[That's simple enough to solve: stick more than one detonator in the same block of explosive. Say, a timer and a radio detonator. It'll blow up if you give the signal, but also when the timer runs down to 00:00:00]<<<<<

—Mickey M. (04:16:37/01-22-54)



## Shaped Explosives

These explosives, designed, manufactured, and marketed by Kohu North America, Inc., are shaped like everyday objects — this allows them to be placed everywhere, without anyone knowing until it is too late! All come with a free Kohu detonator of any type desired by the customer, but of course this is replaceable by any other Kohu detonator of the same size in a few seconds. The cost of the detonator is not included in the explosive's cost as listed below: a button explosive with a micro radio detonator would cost 525 nuyen, 25 for the explosive and 500 for the detonator.

All shaped explosives are made to the nominal weight of the object they represent, and with an outer layer of the same materials as the actual object. This ensures that there is no way to notice the difference between the shaped explosive and the normal object by handling either.

>>>>[I have used these explosives, and I must agree. The only way to notice that you are handling an explosive is by finding the little lid for the detonator, or by using x-ray detection gear.]<<<<<

—Mickey M. (04:21:51/01-22-54)

**LEGAL NOTE:** in many jurisdictions, it is illegal to possess some or any of these –or any other– explosives and/or detonators without the proper permits! Kohu North America, Incorporated, can accept no responsibility for unlicensed use or misuse of these, or any other, Kohu North America, Incorporated, products.

### Game notes

The concealability represents how difficult it is to notice that the shaped explosive is not the everyday object it is supposed to be. The damage code was determined per the rules for explosives on page 242 of **SRII**: the rating multiplied by the square root of the number of kilograms. Damage figures were then adjusted in some cases, to allow for things as shrapnel resulting from the explosion of the casing material.

## Arrow

The Arrow can be used from a distance: it is a normal arrow which can be fired from any bow, fitted with an arrowhead containing 50 grams of C12 and a ceramic fragmentation sleeve (which may be removed, but Damage drops to 3D, Power Level -1/8cm).

The Arrow can be fitted with any mini-detonator in the nose; a pressure detonator will set off the Arrow on impact with a hard surface, but any other detonator can also be fitted. The Arrow weighs .1kg without, and .12kg with, fragmentation sleeve.

The not-very-streamlined design makes that all ranges are reduced by 10%.

Damage	Power Level	Conceal	Availability	Cost	Street Index
5D	-1/25cm	3*	6/48hrs	50¥	2.25

\* = in this case, Concealability represents how easy the Arrow is to conceal. It is obviously not a standard arrow.



**Book**

The Book looks like an old hardcopy book. It is unique in not being simply a book which can't be opened; instead, its pages are made of paper-thin C12! A microdetonator can be fitted in the front cover, which is made of stiff C12, 3mm thick, to give the impression of a hard-cover book. This gives a total of .75 kilograms of C12!

The Book is available in four different models, three of which have the actual text of a classic novel printed on the C12 pages, making it indistinguishable from a real book. The different titles available are appropriate to this Awakened, magically-active world: *The Hobbit* by J.R.R. Tolkien (1937), *Count Zero* by William Gibson (1986), and *Where The Trees Are Neon* by Janette Lydon (2038). The fourth model has blank pages.

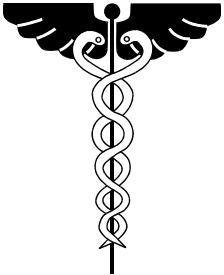

Damage	Power Level	Conceal	Availability	Cost	Street Index
10D	-1/8 cm	20	9/7 days	1,000¥	2.2

**Bottle**

The Bottle comes in three models: .33 liter beer bottle, .75 liter wine bottle, or 1.5 liter soda bottle. Each is available with many different labels and prints of common and rare brands. Each bottle comes filled with the appropriate amount of a spectacular new explosive: a liquid C4 with the density of water, developed by Kohu North America (all rights reserved)! The .33 liter Bottle holds 300 grams, the .75 liter Bottle holds 750 grams, and the 1.5 liter Bottle holds 1.5 kilograms. A micro-detonator can be hidden behind one of the labels.

	Damage	Power Level	Conceal	Availability	Cost	Street Index
.33 liters	3D	-1/25 cm	10	6/5 days	100¥	2
.75 liters	4D	-1/25 cm	10	6/5 days	150¥	2.1
1.5 liters	5D	-1/25 cm	10	8/5 days	200¥	2.2

**Brick**

Available in five different shapes and sizes, all looking like normal bricks used to build houses with, these contain three kilograms of C6 explosive, and can be fitted with a normal detonator. If built into a structure, these can very effectively be used to demolish that structure in an instant.

Damage	Power Level	Conceal	Availability	Cost	Street Index
12D	-1/15 cm	10	6/3 days	300¥	1.5

>>>>[Excellent stuff, except for the fact that most buildings aren't built from bricks anymore...]<<<<<  
 —Keitel(15:05:31/01-14-54)

**Bullet**

These are available in all common calibres, from hold-out pistols to heavy machine guns. The bullet comes with a non-removable mini pressure detonator in the back of the round (so it gets hit by the weapon's firing pin). Each round contains 10 to 20 grams of of C10, which explodes when the round is fired. An exploding round usually sets off all other rounds left in the weapon as well.

Damage	Power Level	Conceal	Availability	Cost	Street Index
1D	-1/10 cm	25	6/3 days	130¥	2



**Button**

Shaped like a shirt or coat button, this contains one gram of C10 explosive, and is fitted with a micro detonator. Comes in five different models in three different colors: white, black, and gold.

Damage	Power Level	Conceal	Availability	Cost	Street Index
1D	-1/10 cm	20	8/4 days	25¥	2.5



**Can**

Shaped like a 0.33-liter soda or beer can, the Can holds 350 grams of C10 high explosive. It can be fitted with a mini-detonator, and to make it all look even more realistic, if a pull detonator is fitted, this connects to the ring used to open a normal soda can! Of course, any other detonator will also fit. Available with prints of Budweiser, Heineken, Pepsi Cola, Seven-Up, or Sisi.

Damage	Power Level	Conceal	Availability	Cost	Street Index
6D	-1/10 cm	22	8/5 days	250¥	1.9

**Compact Disk**

The exact size of a six-centimeter double-sided compact disk, this disk has a wafer-thin explosive charge of 15 grams of C12. Both surfaces are essentially one large laser detonator set for the frequency used by CD-players, so the disk will explode once the CD-player attempts to read from or write to the disk. Available in 15 different prints, both of current and "golden-oldies" albums, as well as a generic computer data CD.

Damage	Power Level	Conceal	Availability	Cost	Street Index
2D	-1/8 cm	16	9/6 days	500¥	4

**Credstick**

This is identical to a normal credstick, and can be plugged into any device that accepts credsticks. It contains 10 grams of C10, and is fitted with a mini detonator.

Damage	Power Level	Conceal	Availability	Cost	Street Index
1D	-1/10 cm	18	8/4 days	50¥	2.25

### Datajack Plug

Fitting into any standard datajack, the Datajack Plug accepts any mini-detonator. It has an explosive charge of 30 grams of C12, most of which is located in the part of the plug that enters the user's skull.

Upon detonation, the person who has the Datajack Plug in his or her datajack resists 6D damage, without the benefit of armor. Anyone in the vicinity of the explosion take 2D damage.

Damage	Power level	Conceal	Availability	Cost	Street Index
6D / 2D	-1/8 cm	10	8/4 days	50¥	2.25

>>>>[This one is nasty, chummers. If you have a datajack, and somebody captures you, they might just shove one of these up your jack. Try anything funny...KABOOM!!]<<<<<  
 —Daryll (04:46:18/01-13-54)

>>>>[Don't get caught.]<<<<<  
 —Wiley (07:19:09/01-13-54)



### Doormat

Either with or without the word "WELCOME" on the Doormat, it is available in 5 different colors. The Doormat contains 2 kilograms of C10 (detonated by a mini detonator), while its upper bristles are made of the flexible-but-unbreakable Strong-i-Plast™, which shoots upward when the Doormat detonates! This gives very much the same effect as a fully-automatic shotgun firing flechette ammunition! The doormat measures 50cm x 75cm.

Anyone standing on the mat gets fried by the flechettes: use twice Impact or normal Ballistic to defend against the explosion, but increase the Power Level of the attack by +2 against unarmored victims. If the armor worn does not protect the legs, treat the target as unarmored (the bristles will shoot right up a long coat, for instance). This is a GM's call, as always. Anyone not standing directly on (or very close to or above) the Doormat only gets the normal blast effects. The flechettes lose 2 off the Power Level for every meter traveled.

Damage	Power Level	Conceal	Availability	Cost	Street Index
14D (16D)	-1/10 cm	12	12/10 days	1,000¥	3.5

### Flower

Resembling a normal plastic flower (available in orchid, rose, and tulip models, each in white, red, or yellow), each Flower contains 20 grams of C12 in the leaves and stem. A micro detonator can be fitted at the top of the stem.

The Damage Code below is for a single flower. If more are grouped together, calculate the Power Level using the formula: [12 x square root(.02 x number of flowers)]. Damage Level remains D. Only one detonator is needed to detonate the whole bunch of flowers.

Damage	Power Level	Conceal	Availability	Cost	Street Index
1D	-1/8 cm	14	9/5 days	45¥	2.5

>>>>[Waste it with flowers...]<<<<<  
 —ASDF(10:19:04/01-14-54)

**Keycard**

The size of a standard card for electronic locks, the Keycard comes in a variety of prints, and even with working magnetic strips, so it can actually be used to open doors with, provided the codes on the strip are valid. (Codes are not included in the purchase price.) The Keycard uses a micro-detonator, and has some five grams of C12.

The Keycard comes in one of five different prints, though custom prints are available on request, as always (at a slight increase in price).



Damage	Power Level	Conceal	Availability	Cost	Street Index
1D	-1/8 cm	24	8/5 days	100¥	3

**Lightbulb**

Looking like a 60 watt lightbulb, this fits virtually all sockets. The Lightbulb is filled with 20 grams of C10, and can be fitted with a mini-detonator (an electrical detonator is perfect: it detonates when someone switches on the light!). The fact that the Lightbulb's glass is opaque white makes it almost indistinguishable from normal lightbulbs.

Damage	Power Level	Conceal	Availability	Cost	Street Index
1D	-1/10 cm	20	4/4 days	125¥	1.9



**Pen**

The Pen's best feature is that it is a normal, everyday pen, filled with high explosive. Not just an imitation that looks like a pen, it comes in five different shapes (from cheap, 100-per-nuyen, to luxury models), and with numerous different, optional prints (custom prints and models available -- call our offices). Each uses a micro detonator, and has some 5 grams of C12 packed inside. A small ink cartridge is featured, so the pen can be used to write with as well.

Damage	Power Level	Conceal	Availability	Cost	Street Index
1D	-1/8 cm	20	9/5 days	75¥	2.75

**Pocket Secretary**

The casing of a Fuchi PS-266 pocket secretary, filled with 400 grams of C8 and an inner ceramic layer, which fragments upon exploding. It must be fitted with a normal-size detonator.

Damage	Power Level	Conceal	Availability	Cost	Street Index
6D	-1/50 cm	16	4/36hrs	250¥	2

**Telephone**

Coming in a two models (hand-held and table-top), the Telephone holds 400 grams of C10. The Telephone accepts a normal detonator, but cannot be used to make actual phone calls.

Both models are available in many different casings of real telephones.

Damage	Power Level	Conceal	Availability	Cost	Street Index
4D	-1/10 cm	23	6/4 days	300¥	2.5

>>>>[An electrical or light detonator is ideal for the table-top model. Just call the number it is supposed to have, so the detonator gets a pulse via the phone line, and bang.]<<<<<

—Dana (19:21:05/01-10-54)

**Optical Chip**

The size of a 50Mp optical chip as used in almost every computer and other electrical device, as well as to record music and data, this fake chip plugs into all standard chip mounts. It is excellent for use with the

Light Detonator, since this will detonate the explosives as soon as the computer tries to write data onto the Chip. Of course, any other micor-detonator will also fit.

The chip has a five-gram charge of C10 explosive.

Damage	Poer Level	Conceal	Availability	Cost	Street Index
1D	-1/10 cm	18	6/4 days	45¥	3

>>>>[To top this all off, here I have a spell (designed by moi) that makes those detonators redundant...

### Explode

When this spell is cast, some or all of the explosives in the area of effect go off. This includes normal explosives such as C4, C12, and similar explosives, as well as ammunition and grenades (up to GM discretion).

Each explosive in the area must roll a resistance test, using is rating for the number of dice to roll, and the Force of the spell as the Target Number. For the caster, the Target Number is the rating of the explosive.

For explosives without a rating (such as ammunition), take its Power Level and divide by 3 to find the rating used against this spell. Someone who has exploding ammunition on his person takes damage as if he were hit by a single round of the exploding ammo, and may roll a Body test to resist damage, but may not use his Combat Pool. The appropriate armor rating (Ballistic or Impact) is substracted from the Target Number for the Body test, but is only one-half (round down) effective.

This spell uses the elemental effects of fire and lightning to ignite the explosives (there are no flames or lighting bolts shooting about).

**Type:** Physical                      **Range:** LOS                      **Target:** see above  
**Duration:** Instant                      **Drain:** [(F/2)+2]D

There's no copyright on the spell, so feel free to give a copy to all your friends.]<<<<<

Gurth (19:50:23/01-05-54)

>>>>[Real nasty spell, this one. Wouldn't want to be in the target area if you're packing a few kilos of C12 plus a couple clips of ammo.]<<<<<

—ASDF (08:27:16/01-14-54)



>>>>[For all you dope-heads out there, following is a file on all sorts and types of **drugs** and other chemicals. Up to you to use them, I don't care if you waste your brain on them, but don't come crying to me if you do, OK? I'll let Wordman explain the rest...]<<<<<  
 —Gurth (as:jk:fh/ae-eu-ha)

Here is a list of drugs our running group came up with. This is the effort of Seth Narins (basic drugs, drugs from fictional sources, and designer drugs), myself (the plants and animals) and Brijesh Gill (real drugs). Thanks to Adam Shostack for reality checks. These drugs are meant to follow the rules in Shadowtech. This file is written as a Neoanarchist Guide rather than a stodgy medicinal journal, so many street rumors are in the actual text rather than the decker comments. Note, take even the main text with a grain of salt, especially where the plants are concerned.

As always, distribute at will, so long as no one profits.

Enjoy,  
 Wordman  
 lward@husc.harvard.edu

>>>>[Like with the SWO Guns file, I didn't alter the text or anything, simply edited it a bit.]<<<<<  
 —Gurth (23:79:59/24-72-08)



```
*****
* Better Living (and Dying) Through Chemistry *
*
* "I'm so high, call me `Your Highness'." *
* -Mike D. *
*****
```

## COMPOUNDS

"Death before dishonor, Drugs before lunch."

—Motto of the Aspen Drug and Gun Club

The substances on this list can generally be found on `Plex streets from drug dealers. Occasionally, you need to find a doctor or a fixer to get some of these. Here's what the entries mean:

**Name:** Normal name of the drug

**AKA:** Also Known As. These are common street names for these drugs in various parts of the world.

**Inspiration:** From where we stole this idea, or who created it.

**Speed:** The speed with which the drug takes effect.

**Vector:** How the drug must be administered.

**Duration:** How long the drug lasts.

**Effects:** These are the primary effects of the drug which all take place throughout the duration of the drug's effect.

**Crash Effects:** After the drug stops working, these effects hit the body. The duration of these effects should be twice the duration of the drug, unless otherwise noted.

**Permanent Effects:** These effects work on the body after the drug wears off, like crash effects, but will be permanent. Most of these entries have a

saving roll to avoid these effects. Unless otherwise stated, these permanent effects must be resisted each time the drug is taken.

**Addiction Effects:** These effects apply, in addition to all the other effects, when the user becomes addicted. All effects are permanent unless otherwise noted. Most effects have a saving roll to avoid them.

One note on effects: any drug that has Stim Patch-like effects may be detrimental to a magician's Magic Rating just as Stim Patches are (see **SRII** pg.115 and 250). Also, the block-all referred to is from an issue of **Kage** and has the following effects: If you are under the effects of a block all, each time you are injured, you roll a number of dice equal to your Willpower plus the rating of the block-all against a target number equal to the number of physical damage boxes taken. Each success on this test allows you to ignore the effects of 1 box of physical damage. The damage is still there, however.

## Depressants

"Alcohol is very important for young people because it provides a sort of `liquid adulthood'. If

you are young and you drink a great deal it will spoil your health, slow your mind, make you fat--in other words, turn you into an adult."

—P.J. O'Rourke, Modern Manners

**Alcohol**

**AKA:** eth, courage, fire water, booze, etc.

**Inspiration:** reality

**Addiction:** 2m

**Tolerance:** 3

**Strength:** 50

**Speed:** 1d6 minutes

**Vector:** Ingestion

**Duration:** 1d6/2 hours

**Cost/Dose:** 1-10¥

**Street Index:** 0.8

**Legality:** Legal

**Availability:** Always

**Effects:** Charisma -1, Quickness -2, Intelligence -2, Willpower -1 [Resist all with Body (10-(proof/20))], clumsiness, unrestrained behavior, block-all (proof/25), tranq(proof/20)

**Crash Effects:** Quickness -1, Body -2, Intelligence -1, nausea, headaches, irritability

**Barbiturates**

**AKA:** Amytal, phenobarbital, damn it all

**Inspiration:** reality

**Addiction:** 4m,3p

**Tolerance:** 3

**Strength:** 5

**Speed:** 10 minutes

**Vector:** Ingestion

**Duration:** 1-16 hours

**Cost/Dose:** 1¥

**Street Index:** 0.8

**Legality:** 6P-M1

**Availability:** 4/3 hours

**Effects:** Charisma -1, Quickness -2, Intelligence -2, Willpower -1, clumsiness, sleepiness, calm, block-all(1), Tranq(5)

**Crash Effects:** Quickness -1, Body -2, Intelligence -1, nausea, headaches, irritability

**Benzodiazepines**

**AKA:** Valium, redundant, etc.

**Inspiration:** reality

**Addiction:** 2m,2p

**Tolerance:** 5

**Strength:** 5

**Speed:** 10 minutes

**Vector:** Ingestion

**Duration:** 4-8 hours

**Cost/Dose:** 1¥

**Street Index:** 0.9

**Legality:** 6P-M1

**Availability:** 4/3 hours

**Effects:** Charisma -1, Quickness -3, Intelligence -2, Willpower -1, clumsiness, sleepiness, calm, block-all(3), tranq(6)

**Crash Effects:** Quickness -1, Body -2, Intelligence -1, headaches, irritability



**Butaqualide**

**AKA:** beauties

**Inspiration:** Effinger novels

**Addiction:** 5m

**Tolerance:** 3

**Strength:** 10

**Speed:** 1d6 minutes

**Vector:** Ingestion

**Duration:** 1d6+1 minutes

**Cost/Dose:** 20¥

**Street Index:** 2.5

**Legality:** 5P-M1

**Availability:** 5/1 hour

**Effects:** Quickness -3, Willpower +1, Charisma +2, euphoria, sleepiness, tranq(4), block-all(4)

**Crash Effects:** irritability

**Chloral Hydrate**

**AKA:** drop, noctec

**Inspiration:** reality

**Addiction:** 4m,3p

**Tolerance:** 3

**Strength:** 5

**Speed:** 30 seconds

**Vector:** Injection

**Duration:** 5-8 hours

**Cost/Dose:** 2¥

**Street Index:** 1.0

**Legality:** 4P-M1

**Availability:** 5/4 hours

**Effects:** Quickness -3, Intelligence -2, Willpower -2, clumsiness, sleepiness, calm, block-all(3), tranq(6)

**Crash Effects:** Quickness -2, Body -2, Intelligence -1, nausea, headaches

**Glutethimide**

**AKA:** glue, Chevy Chase, lemonade, doriden  
**Inspiration:** reality  
**Addiction:** 3m,4p  
**Tolerance:** 4  
**Strength:** 3  
**Speed:** 10 minutes  
**Vector:** Ingestion  
**Duration:** 4-8 hours  
**Cost/Dose:** 3¥  
**Street Index:** 1.0  
**Legality:** 4P-M1  
**Availability:** 5/4 hours  
**Effects:** Charisma -1, Quickness -4, Intelligence -2, Willpower -1, extreme clumsiness, hallucinations, calm, block-all(1), tranq(3)  
**Crash Effects:** Quickness -1, Body -2, Intelligence -1, nausea, headaches, irritability, anxiety, insomnia  
**Addiction Effects:** Withdrawal from glutethimide is painful, causing convulsions, and possibly death.

**Marijuana**

**AKA:** grass, weed, hashish, dubich, ganja  
**Inspiration:** reality  
**Addiction:** 3m  
**Tolerance:** 3  
**Strength:** 10  
**Speed:** 2d6/1d6 minutes  
**Vector:** Inhalation/Ingestion  
**Duration:** 4d6 minutes/1d3 hours  
**Cost/Dose:** 4¥/20¥  
**Street Index:** 0.5  
**Legality:** 6-M1  
**Availability:** 3/60 minutes  
**Effects:** Quickness -2, Intelligence -1, Charisma +2, Willpower -1, Body -1, Reaction -2, lethargy, euphoria, block-all (2)  
**Crash Effects:** Charisma -1, Reaction -1, Willpower -1, hunger, sensory sensitivity, Stimulant(1)  
**Permanent Effects:** Artistic skills +1 once per month of use [Charisma(6), +1 maximum total increase], Charisma +1 once per month use [Willpower(6), +1 maximum total increase]

**Methaqualone**

**AKA:** alone, solo, quaaludes, ludes

**Inspiration:** reality  
**Addiction:** 4m,4p  
**Tolerance:** 4  
**Strength:** 2  
**Speed:** 10 minutes  
**Vector:** Ingestion  
**Duration:** 4-8 hours  
**Cost/Dose:** 3¥  
**Street Index:** 1.2  
**Legality:** 4P-M1

**Availability:** 4/3 hours  
**Effects:** Charisma -1, Quickness -2, Intelligence -2, Willpower -1, clumsiness, hallucinations, calm, block-all(1), tranq(3)  
**Crash Effects:** Quickness -1, Body -2, Intelligence -1, nausea, headaches, irritability, anxiety, insomnia  
**Addiction Effects:** Withdrawal from Methaqualone is painful, causing convulsions, and possibly death.



>>>>[This also causes women to loose their morals, if ya catch m' meaning. Paradoxically, it kills the libido in men, which means that a couple on ludes is pretty fucked. Or not fucked, as the case may be.]<<<<<  
 —Babble (06:14:38/09-13-54)

**Nicotine**

**AKA:** death sticks, smokes, cancer in a nice easy to use package, etc.  
**Inspiration:** reality  
**Addiction:** 3m  
**Tolerance:** 1  
**Strength:** 20  
**Speed:** Immediate  
**Vector:** Inhalation, dermal, ingestion  
**Duration:** 3d6+3 minutes  
**Cost/Dose:** 2¥/pack  
**Street Index:** 0.8  
**Legality:** Legal  
**Availability:** Always  
**Effects:** Willpower +1, Charisma -1, relaxant, Tranq (2)  
**Crash Effects:** Willpower -1, irritability, anxiety

**Paxium**

**AKA:** joy, U.N., later, micky, slug  
**Inspiration:** Effinger novels  
**Addiction:** 2m

**Tolerance:** 4  
**Strength:** 20  
**Speed:** 2d6 minutes  
**Vector:** Ingestion  
**Duration:** 4d6 minutes  
**Cost/Dose:** 5¥  
**Street Index:** 2.5  
**Legality:** 6P-M1  
**Availability:** 3/60 minutes  
**Effects:** reduced aggressiveness, calm, sleepiness, tranq(6)  
**Crash Effects:** Willpower, Body, Quickness and Charisma -3 for 2d6 minutes [Willpower(5)], nausea, joint stiffness

**Sonniene**

**AKA:** sunnies, rook, eclipse, summoner  
**Inspiration:** Effinger novels  
**Addiction:** 4m  
**Tolerance:** 3  
**Strength:** 5  
**Speed:** 2d6 minutes  
**Vector:** Ingestion  
**Duration:** 1d6+1 hours  
**Cost/Dose:** 80¥  
**Street Index:** 3.0  
**Legality:** 4-M1  
**Availability:** 4/60 minutes  
**Effects:** Willpower and Charisma +2, Intelligence -2, euphoria, delusions of invulnerability, block-all(4)  
**Crash Effects:** Mental Attributes -2 for 4d6 minutes, tremors, timidity, depression  
**Permanent Effects:** Willpower and Charisma -1 [Willpower(5) for each]  
**Addiction Effects:** Willpower and Charisma -1 per month [Willpower(5) for each]

**Designer Drugs**

"A dealer? Hell, no, man. I'm a dream-sculptor."  
 —Madge, 2054

**Schwarzeneine**

**AKA:** Coranol, back, burnout, gung-ho  
**Inspiration:** Seth  
**Addiction:** 6p

**Tolerance:** 4  
**Strength:** 5  
**Speed:** 1d6 minute  
**Vector:** Injection  
**Duration:** 1d3 hours  
**Cost/Dose:** 45¥  
**Street Index:** 3.5  
**Legality:** 3-M1  
**Availability:** 8/3 hours  
**Effects:** Intelligence and Quickness -3, Strength and Will-power +3, Reaction +6, aggressiveness, risk-taking, single-mindedness, as active Pain Editor  
**Crash Effects:** Intelligence, Quickness and Strength -1 for 1d6 hours, Quickness and Strength -1 for 1d6 days, tractability, double nature, lethargy, moderate stun wound



**Shades**

**AKA:** cool, strut  
**Inspiration:** Seth  
**Addiction:** 5m  
**Tolerance:** 2  
**Strength:** 5  
**Speed:** 30 minutes  
**Vector:** Ingestion  
**Duration:** 1d3 hours  
**Cost/Dose:** 30¥  
**Street Index:** 2.0  
**Legality:** 5-M1  
**Availability:** 4/60 minutes  
**Effects:** Strength and Intelligence -1, Charisma and Willpower +2, euphoria, subtle "cool", block-all(1), stimulant(1)  
**Crash Effects:** Willpower, Charisma, Strength and Quickness -1 for 1d6 hours, increased appetite (x2), possible sexual dysfunction [Body(6)], Light Stun wound

**NuYou**

**AKA:** sailor, nuyen, virgin, charm, binder  
**Inspiration:** Seth  
**Addiction:** 6m  
**Tolerance:** 3  
**Strength:** 10  
**Speed:** 3d6 hours  
**Vector:** Injection  
**Duration:** 1d6 days

**Cost/Dose:** 350¥  
**Street Index:** 3.0  
**Legality:** 4-M1  
**Availability:** 4/2 hours  
**Effects:** Charisma +4, Body +2, Quickness and Strength -1  
**Crash Effects:** Charisma -3 for 1d6 weeks [time divided by number of successes from Body(8)], physical deterioration, anxiety  
**Addiction Effects:** Body and Charisma -1 per week [Body(5) for each]

**Musk**

**AKA:** skunk, slink, strut, charlie, vamp  
**Inspiration:** Seth  
**Addiction:** 3m  
**Tolerance:** 3  
**Strength:** 20  
**Speed:** 2d6 hours  
**Vector:** Injection  
**Duration:** 2d6 hours  
**Cost/Dose:** 250  
**Street Index:** 2.0  
**Legality:** 6-M1  
**Availability:** 3/60 minutes  
**Effects:** Charisma +2(vs. opposite sex)/-2(vs. same sex), sexual aggressiveness, pheromone stimulation  
**Crash Effects:** Charisma -1

>>>>[Great for meets.]<<<<<  
 —Charmer (04:12:53/09-10-54)

>>>>[Unless you have tailored pheromones, which go completely out of control when this drug is in effect.]<<<<<  
 —Tom (23:54:32/09-13-54)

**FoolKiller**

**AKA:** ripper, charge, egg in a pan, joker, Herc  
**Inspiration:** Cyberpunk 2020  
**Addiction:** 5p  
**Tolerance:** 2  
**Strength:** 10  
**Speed:** Immediate  
**Vector:** Inhalation  
**Duration:** 1d6 days  
**Cost/Dose:** 35¥  
**Street Index:** 2.5  
**Legality:** 3-M1  
**Availability:** 8/3 hours  
**Effects:** Charisma and Willpower +3, Body +2, Intelligence and Quickness -1, feeling of

invulnerability, unshakable confidence, zealotry, aggressiveness, as activated Pain Editor

**Crash Effects:** Body -1, Willpower +1 for 1d6 days [Willpower(6)], Quickness -2 for 1d6 days [a Body(6) save will cut to -1], Intelligence -1 for 1d6 days  
**Permanent Effects:** -1 physical box per dose [Body(6)], Body -2(vs. pathogens and poisons) [Body(6)]  
**Addiction Effects:** -1 physical box per week [Body(6)], -1 physical box per month [Body(6)]



**Diamond-Four**

**AKA:** straight flush, cleric, stitch, street doc, healing anger, berserker  
**Inspiration:** Cyberpunk  
**Addiction:** 2p  
**Tolerance:** 2  
**Strength:** 10  
**Speed:** Immediate  
**Vector:** Injection  
**Duration:** 2d6 days  
**Cost/Dose:** 1,500¥  
**Street Index:** 3.5  
**Legality:** 3P-M1  
**Availability:** 10/2 days  
**Effects:** Body +4(vs. poisons and pathogens), Willpower +2(vs. pain), Quickness -2, Intelligence -2, irrational fears/phobias, beserker rage, +2 physical box [10 max], Tranq(6)  
**Crash Effects:** Quickness and Intelligence -2 for 1d6 days  
**Permanent Effects:** +1 physical box (to 10 max) [and passing a Body(8) will give one more]

>>>>[This drug is wonderful. It is mainly for use against nerve gas, but it can repair some of the more sinister forms of cell damage cause by some of the other drugs on this list.]<<<<<  
 —Baby (07:18:43/09-14-54)

**Genesios Three**

**AKA:** Black thunder

**Inspiration:** Walter Jon Williams

**Addiction:** 2m

**Tolerance:** 5

**Strength:** 20

**Speed:** 1d6 turns

**Vector:** Injection, Ingestion

**Duration:** 1d6 + 17 hours

**Cost/Dose:** 1,000¥

**Street Index:** 8.5

**Legality:** 4P-M1

**Availability:** 14/2 weeks

**Effects:** Intelligence +4, slight buzzing euphoria

**Crash Effects:** none

**Permanent Effects:** G3 rebuilds, repairs and stimulates growth of nerve cells (which do not normally grow at all).

## Hallucinogens

"The hallucinogenic drugs are not rude per se. But it can be difficult to observe the niceties of etiquette when you're being chased down the street by a nine-headed cactus demon."

—P.J. O'Rourke, Modern Manners

## Ecstasy

**AKA:** XTC

**Inspiration:** Seth

**Addiction:** 4m

**Tolerance:** 4

**Strength:** 20

**Speed:** 2/2/30 minutes

**Vector:** Inhalation/Injection/Ingestion

**Duration:** 6d6 minutes

**Cost/Dose:** 150¥

**Street Index:** 4.0

**Legality:** 4-M1

**Availability:** 5/7 hours

**Effects:** Charisma +5, Willpower -3, Quickness +4, sexual tension and prowess, euphoria, aggressiveness, mild hallucinations, extreme sensory stimulation [+3 perception, +3 T# to resist pain], as stimulant patch (2), Quickness-based skills +2

**Crash Effects:** Quickness -3, Strength -3, Willpower -3, possible sexual dys-function, sexual hun-ger, Deadly Stun wound, Quickness-based skills -2, Reac-tion-based skills -1

**Permanent Effects:** Sterility [Body(4)]

>>>>[There was a popular drug called XTC around the turn of the century,

which some people still take. This is not it. So make sure you know what you're buying.]<<<<<

—Caveat

(21:14:34/09-16-54)



## LSD

**AKA:** acid, Lucy, lucid, wow, LDS, Spocko

**Inspiration:** reality

**Addiction:** 1m

**Tolerance:** 2

**Strength:** 4

**Speed:** 20 minutes

**Vector:** Ingestion

**Duration:** 1d6+2 hours

**Cost/Dose:** 5¥/dose but 200¥/100 tabs

**Street Index:** 1.5

**Legality:** 5-M1

**Availability:** 4/7 hours

**Effects:** Quickness -3, Intelligence -4(cognitive), Willpower -3, possible uncontrolled astral perception [Essence(16), number of successes x 10 is what percent of the duration time you are astral], Charisma -2, withdrawal from reality, intense hallucinations, as stimulant patch (3), as block-all(3)

**Crash Effects:** Withdrawal from reality, lethargy, concentration-based activities -1, Serious Stun wound

**Permanent Effects:** -1 physical box [Body(8)], Willpower -1 [Willpower(8)]

**Addiction Effects:** Intelligence, Charisma, Reaction -1 per month [Body(8) for each], artistic skills +1 per month [Charisma(8), +2 maximum increase], Magic Theory +1 per month [Intelligence(8), +1 maximum increase]

## MDA, MDMA, and other Amphetamine variants

**AKA:** VR, Yeager, boxy

**Inspiration:** reality

**Addiction:** 2m

**Tolerance:** 2

**Strength:** 6

**Speed:** 20 minutes

**Vector:** Ingestion

**Duration:** 4-24 hours

**Cost/Dose:** 10¥

**Street Index:** 1.7

**Legality:** 4-M1

**Availability:** 4/7 hours

**Effects:** Quickness -2, Intelligence -4(cognitive), Willpower -2, Charisma -1, withdrawal from reality, intense hallucinations, as stimulant patch (4), as block-all(4)

**Crash Effects:** Withdrawal from reality, lethargy, concentration-based activities -1, Serious Stun wound

**Addiction Effects:** Intelligence, Charisma, Reaction -1 per month [Body(8) for each]

>>>>[MDA is sometimes called Zen. MDMA is usually known as Exstasy. Both of these names appear elsewhere in this list, but they are different drugs. One of the problems with street culture is that it isn't very creative.]<<<<<

—Caveat (21:14:59/09-16-54)

### Mescaline

**AKA:** meska, mask, projects, Ghost Dance

**Inspiration:** reality

**Addiction:** 2m

**Tolerance:** 2

**Strength:** 4

**Speed:** 5 minutes

**Vector:** Air

**Duration:** 8-12 hours

**Cost/Dose:** 80¥

**Street Index:** 2.0

**Legality:** 4-M1

**Availability:** 4/5 hours

**Effects:** Quickness -2, Charisma -2, Reaction -2, Intelligence -2(cognitive)/+2 perceptive, Willpower -2, possible uncontrolled astral perception [Essence(16), number of successes x 10 is what percent of the time you are astral], magical theory +3, dream state trance, intense hallucinations

**Crash Effects:** Drowsiness, light sensitivity, increased appetite

**Permanent Effects:** Magical Theory +1 [Intelligence(12), once per month of use], Charisma +1 [Will-power(12), once per month of use, +1 maximum increase], withdrawal from reality with continual use

**Addiction Effects:** Intelli-gence -1 per month [Body (8)], Willpower -1 per month [Body(8)]

### Phencyclidine

**AKA:** PCP, dust, angel dust, stage, theatre, JWB

**Inspiration:** reality

**Addiction:** 5m

**Tolerance:** 4

**Strength:** 2

**Speed:** 2 minutes

**Vector:** Injection

**Duration:** 1-4 days

**Cost/Dose:** 25¥

**Street Index:** 2.5

**Legality:** 4-M1

**Availability:** 8/14 hours

**Effects:** Body, Strength, Willpower +3, Quickness -3, Intelligence -4 (cognitive), Willpower -3, Charisma -2, withdrawal from reality, intense hallucinations, as stimulant patch (5), as block-all(5)

**Crash Effects:** Withdrawal

from reality, lethargy, concentration-based activities -2, Serious Stun wound

**Permanent Effects:** -1 physical box [Body(8)], Willpower -1 [Willpower(8)]

**Addiction Effects:** Intelligence, Charisma, Reaction -1 per month [Body(8) for each]



### Ribopropylmethionine

**AKA:** RPM, Round-baby

**Inspiration:** Effinger novels

**Addiction:** 8p

**Tolerance:** 2

**Strength:** 2

**Speed:** 3 minutes

**Vector:** Injection

**Duration:** 1d6+1 minutes

**Cost/Dose:** 100¥

**Street Index:** 3.0

**Legality:** 3-M1

**Availability:** 10/7 hours

**Effects:** Quickness -4, Intelligence -2, Willpower -6, Charisma -4, Strength +2, terror, fear, extreme hallucinations (personal fears), as stimulant patch(8), as block-all(6)

**Crash Effects:** Tremors, paranoia, abject fear, recurring hallucinations, concentration-based activities -2, extreme sensitivity to fear, adrenal overload [automatic Deadly wound to adrenal pump bioware]

**Permanent Effects:** Quickness -1 [Body(8)], Willpower and Charisma -1 [Willpower(8) for each]

**Addiction Effects:** Quickness, Willpower, Intelligence -1 per month

**Zen**

**AKA:** Wu-li, bluemind, blewmind, in

**Inspiration:** Seth

**Addiction:** 5m

**Tolerance:** 3

**Strength:** 10

**Speed:** 10 minutes

**Vector:** Inhalation

**Duration:** 1d6+3 hours

**Cost/Dose:** 120¥

**Street Index:** 3.0

**Legality:** 4-M1

**Availability:** 5/10 hours

**Effects:** Charisma +4, Willpower -2, Strength -2, Quickness +2, Reaction -2, serenity, calmness, withdrawal from reality, hallucinations, block-all(3)

**Crash Effects:** Charisma -1, Strength -1, Reaction -1, Artistic Skills +1, self-doubt, mental turbulence, chaotic emotions, concentration-related tasks +2 T#, sensory distraction [-2 perception]

>>>>[All right. One more time. This is not another drug called Zen. See MDA, above.]<<<<<  
—Caveat (21:14:34/09-16-54)

**Narcotics**

"Heroin and the other 'downs', natural and synthetic, are not polite. These drugs effectively eliminate the painful aspect of existence, which, now-adays, is almost all of it."

—P.J. O'Rourke, Modern Manners

**Heroin**

**AKA:** H, horse, smack, K.R.

**Inspiration:** reality

**Addiction:** 5m,5p

**Tolerance:** 3

**Strength:** 3

**Speed:** 1 turn

**Vector:** Injection

**Duration:** 1d3 hours

**Cost/Dose:** 20¥

**Street Index:** 2.5

**Legality:** 3-M1

**Availability:** 5/2 hours

**Effects:** Body -2, Willpower +2, Quickness -1, Intelligence -1, Charisma -2, withdrawal from reality, block-all(6)

**Crash Effects:** Stress

**Permanent Effects:**

Body -1 [Body(5)], Charisma -1 [Willpower(6)]

**Addiction Effects:** Body -1 per month [Body(5)], Charisma -1 [Body(6)], -1 physical box per month, -1 mental box per month



**Hydromorphone**

**AKA:** Pain water, dilaudid

**Inspiration:** reality

**Addiction:** 4m,4p

**Tolerance:** 5

**Strength:** 7

**Speed:** 1 minute

**Vector:** Injection

**Duration:** 3-6 hours

**Cost/Dose:** 250¥

**Street Index:** 1.5

**Legality:** 3P-M1

**Availability:** 5/6 hours

**Effects:** Charisma -1, Intelligence -4, Willpower +3 (vs. pain), tranquilized, block-all(7)

**Crash Effects:** pain-sensitivity (+1 to all wound category modifiers), irritability, tremors

**Addiction Effects:** Willpower -1 per dose [Willpower(6)]

**Meperidine**

**AKA:** reaper, k'pla, demerol

**Inspiration:** reality

**Addiction:** 4m,4p

**Tolerance:** 5

**Strength:** 4

**Speed:** 1 minute

**Vector:** Ingested, injected

**Duration:** 12-24 hours

**Cost/Dose:** 500¥

**Street Index:** 2.5

**Legality:** 3-M1

**Availability:** 6/6 hours

**Effects:** Strong euphoria, Charisma -2, Intelligence -3, Reaction -2, Willpower +2 (vs. pain), tranquilized, block-all(6), nausea

**Crash Effects:** irritability, concentration-based tests +3 Target Number, Willpower -2 (vs. pain), cramps, nausea, chills

**Addiction Effects:** Willpower -1 to -2 per dose [Willpower(5), twice], Willpower, Intelligence and Charisma -1 per month [Willpower(4) for each]

### Methadone

**AKA:** Crystal Meth, annihilatrix, dominatrix

**Inspiration:** reality

**Addiction:** 2m,3p

**Tolerance:** 3

**Strength:** 5

**Speed:** 1 minutes

**Vector:** Inhalation (powder)

**Duration:** 3-6 hours

**Cost/Dose:** 50¥

**Street Index:** 2.0

**Legality:** 4-M1

**Availability:** 5/6 hours

**Effects:** Intelligence -1, Willpower +1 (vs. pain), tranquilized, block-all (5), euphoria

**Crash Effects:** concentration-based tests +2 Target Number, Willpower -2 (vs. pain), watery eyes, loss of appetite, cramps.

**Addiction Effects:** Willpower, Intelligence and Charisma -1 per month [Willpower(4) for each]

### Morphine

**AKA:** morph, shifter, no-brain

**Inspiration:** reality

**Addiction:** 4m,4p

**Tolerance:** 4

**Strength:** 10

**Speed:** 1 minute

**Vector:** Injection

**Duration:** 3-6 hours

**Cost/Dose:** 150¥

**Street Index:** 1.25

**Legality:** 3P-M1

**Availability:** 4/3 hours

**Effects:** Charisma -1, Intelligence -2, Willpower +2 (vs. pain), tranquilized, block-all(6)

**Crash Effects:** pain-sensitivity (+2 to all wound category modifiers), irritability, concentration-based tests +2 Target Number, Willpower -2 (vs. pain)

### Addiction Effects:

Willpower -1 per dose [Willpower(6)], Willpower, Intelligence and Charisma -1 per month [Willpower(6) for each]

### Opium

**AKA:** Pipedream

**Inspiration:** reality

**Addiction:** 4m,4p

**Tolerance:** 3

**Strength:** 15

**Speed:** 10 minutes

**Vector:** Inhalation

**Duration:** 3-6 hours

**Cost/Dose:** 50¥

**Street Index:** 1.25

**Legality:** 5P-M1

**Availability:** 6/1 day

**Effects:** Charisma -2, Intelligence -1, Willpower +2 (vs. pain), tranquilized, block-all(6)

**Crash Effects:** irritability, tremors, panic, drowsiness, chills



### Stimulants

"It is very rude to try crack a few times and not get addicted. This could throw any number of hysterical politicians and overwrought public health experts out of work."

—P.J. O'Rourke, Modern Manners

### Amphetamines

**AKA:** speed, benxies, dexies

**Inspiration:** reality

**Addiction:** 5p

**Tolerance:** 3

**Strength:** 6

**Speed:** 5 minutes

**Vector:** Ingestion

**Duration:** 2-4 hours

**Cost/Dose:** 75¥/50 tablets

**Street Index:** 1.5

**Legality:** 4P-M1

**Availability:** 4/3 hours

**Effects:** Charisma -1, Willpower -1, Quickness +1, Perception +1, increased alertness, excitability, euphoria, increased pulse and blood pressure, insomnia, loss of appetite.

**Crash Effects:** depression, apathy, disorientation, irritability, long period of sleep, headache (L Stun wound).

### Brown Study

**AKA:** Net focus, karma, soma, silver

**Inspiration:** Cyberpunk 2020

**Addiction:** 1m

**Tolerance:** 4

**Strength:** 10

**Speed:** 30 minutes

**Vector:** Ingestion

**Duration:** 2d6 hours

**Cost/Dose:** 35¥

**Street Index:** 3.0

**Legality:** 3P-M1

**Availability:** 6/6 hours

**Effects:** Quickness -2, Strength -2, Reaction -4, Willpower +2, Intelligence +4, Technical/Knowledge skills +3, intense mental concentration, resistance to distractions, insomnia, possible psychoactive journey [Body(12-Body)]; 1d6+1 hours in length

**Crash Effects:** Quickness and Strength -2 for 3d6 hours upon recovery [resist with a Body(10) roll for each], lethargy, increa-sed appetite (x3), Mod-erate Stun wound.

### Caffeine

**Inspiration:** reality

**Addiction:** 1m

**Tolerance:** 3

**Strength:** 50

**Speed:** 30 minutes

**Vector:** Ingestion

**Duration:** 1d6 hours

**Cost/Dose:** 5¥/100 tablets

**Street Index:** 1.0

**Legality:** Legal

**Availability:** always

**Effects:** Charisma -1, Willpower -1, anxiety, tremors, hyperactivity, reduced appetite, acts as stimulant patch (1)

**Crash Effects:** Light Stun wound

### Cocaine

**AKA:** coke, nose-candy, exec,

$C_{17}H_{21}NO_4$ , snow

**Inspiration:** reality

**Addiction:** 6p

**Tolerance:** 3

**Strength:** 5

**Speed:** Immediate

**Vector:** Inhalation

**Duration:** 1d3 hours

**Cost/Dose:** 10¥

**Street Index:** 2.0

**Legality:** 3-M1

**Availability:** 4/60 minutes

**Effects:** Quickness +1, Intelligence +1, Charisma -2, Body -2, aggressiveness, risk-taking, block-all(3)

**Crash Effects:** Depression, hyperactivity, Moderate Stun wound

**Permanent Effects:** Charisma -1 [Will-power(6)]

**Addiction Effects:** Body -1 per month [Will-power(6)], Willpower and Intelligence -1 per month [Willpower(4) for each]



### Endorphins

**AKA:** 'dorph, Fred Dorfman, inga, hoo'a hoo'a

**Inspiration:** Cyberpunk 2020

**Addiction:** 4p

**Tolerance:** 4

**Strength:** 5

**Speed:** 1d6 minutes

**Vector:** Injection

**Duration:** 1d3 hours

**Cost/Dose:** 30¥

**Street Index:** 3.0

**Legality:** 3-M1

**Availability:** 6/3 hours

**Effects:** Intelligence and Quickness -2, Strength and Willpower +2, Body +1, reduced sensitivity to pain [-2 Target Number], single-mindedness, block-all(6), tranq(3), +2 Target Number to inflict pain

**Crash Effects:** Intelligence, Quickness and Strength -1 for 1d6 hours [Body(4)], irritability, hyperactivity, aggressiveness, Light Stun wound, Light physical wound

**Permanent Effects:** Charisma -1 [Willpower(4)]

**Addiction Effects:** Quickness -1 per dose [Body (4)], Charisma -1 per month [Willpower(4)]

**J**

**AKA:** Johnny Mnemonic, recall (pronounced as both "recall" and "wrek-all"), squealer, this-is-your-life, honto

**Inspiration:** Traveller 2300

**Addiction:** 1m

**Tolerance:** 1

**Strength:** 50

**Speed:** 1 minute

**Vector:** Ingestion

**Duration:** 4d6 minutes

**Cost/Dose:** 600¥

**Street Index:** 4.0

**Legality:** 3P-M1

**Availability:** 10/3 hours

**Effects:** Intelligence -4(cognitive)/+10(mnemonic), Willpower -6, extreme talkativeness, complete willingness to answer questions about memories, uncontrolled rambling about personal recollections, uncontrolled veracity

**Crash Effects:** complete memory loss about duration of dosage

**Methylphenidate**

**AKA:** skippy, jif, ritalin

**Inspiration:** reality

**Addiction:** 3p

**Tolerance:** 5

**Strength:** 4

**Speed:** 5 minutes or 1 minute

**Vector:** Ingestion, Inhalation, Injection

**Duration:** 2-4 hours

**Cost/Dose:** 25¥

**Street Index:** 1.8

**Legality:** 4P-M1

**Availability:** 4/3 hours

**Effects:** Quickness +2, Perception +1, increased alertness, excitability, euphoria, increased pulse and blood pressure, insomnia, loss of appetite.

**Crash Effects:** depression, apathy, disorientation, irritability, long period of sleep, headache (M Stun wound).

**Phenmetrazine**

**AKA:** Devo

**Inspiration:** reality

**Addiction:** 5p

**Tolerance:** 4

**Strength:** 5

**Speed:** 5 minutes or 1 minute

**Vector:** Ingestion or Injection

**Duration:** 2-4 hours

**Cost/Dose:** 75¥/10 tablets

**Street Index:** 1.5

**Legality:** 4P-M1

**Availability:** 5/3 hours

**Effects:** Willpower -2,

Quickness +1,

increased alertness,

excitability, euphoria,

increased pulse and

blood pressure, insomnia,

loss of appetite.

**Crash Effects:** depression,

apathy, disorientation,

irritability, long period of

sleep, headache (L Stun

wound).



**Spaz**

**AKA:** bitch, shrew, Mr. Ugly drivin'

**Inspiration:** Cyberpunk 2020

**Addiction:** 5p

**Tolerance:** 1

**Strength:** 5

**Speed:** Immediate

**Vector:** Air, ingestion

**Duration:** 2d6 hours

**Cost/Dose:** 10¥

**Street Index:** 1.5

**Legality:** 4-M1

**Availability:** 8/24 hours

**Effects:** Charisma -3, Willpower -1, Reaction +2, Intelligence -1(cognitive)/+1(perceptive), Reaction-based skills +2, hyperactivity, aggressive behavior, muscle tremors, reduced appetite, as stimulant patch (2)

**Crash Effects:** Neural dysfunction (tremors, memory lapses, paralysis), Moderate Stun wound

**Addiction Effects:** Quickness and Charisma -1 per month, -1 physical box per month

**Triphetamines**

**AKA:** Tri-phets

**Inspiration:** Effinger novels

**Addiction:** 2m

**Tolerance:** 4

**Strength:** 5

**Speed:** 1 minute

**Vector:** Ingestion

**Duration:** 1d6 hours

**Cost/Dose:** 25¥/50 tablets

**Street Index:** 1.5

**Legality:** 5P-M1

**Availability:** 5/3 hours

**Effects:** Charisma -2, Willpower -2, Quickness +1, Reaction +1, hyperactivity, detachment from reality, reduced appetite, increased metabolic rate (x2), as stimulant patch (1)

**Crash Effects:** depression, lethargy, nausea [Willpower (4)], Light Stun wound

## FLORA

Plants have long been used for their effects on the human body and other forms of life. What follows is a list of plants which contain chemicals or properties which may be of interest to the researcher or Shadowrunner. Each entry is described by the following categories:

**Name:** The name of the plant

**Taxonomy:** The scientific name for the plant

**Cost:** Cost of plants is kind of a weird area. Sometimes it is the cost to get the plant which is listed, sometimes the cost of the main chemical in the plant. It's not perfect, but it's as good as our information could get.

**Street Index:** This can vary widely depending on where you are. If you live in the NAN, for example, it'd probably be cheaper to buy peyote than it would be in Seattle.

**Legality:** This is baseline Seattle, as always. Most of these plants are legal, but often the chemicals in them are not. Go figure.

**Availability:** This can vary very widely, even more so than the drugs above. Many dealers will always have some of a given plant in stock, while another will never carry it. Consider the number to be a measure of the plants rarity rather than whether a particular fixer will have it. The time is how long it takes to find someone that has it, not how long it will take that person to get it.

**Appearance:** This is a description of the plant, so you might recognize it.

**Climate:** Rough climate or locality in which the plant grows

**Effects:** The effects.

Normally, your friendly neighborhood drug dealer isn't gonna know shit about most of this stuff. You need a talismonger, usually. Sometimes, you can score some of the medicinal chemicals from a hospital or street doc, but usually, your vitalis (that's "vital talismonger" for non-Denverites) is who you need to see. This can be a problem, because `mongers don't usually have the networks of fixers or dealers, so it's often a pot luck

if vitalis carries what you need. If not, you'll probably have to find another `monger. You may even have to leave town to get what you want.

One last thing: some nations have really odd laws on importation of plants like this. If a plant seems really expensive, you can bet that it's taxed to hell and back, or barred from entry.



### Aloe (Awakened)

**Taxonomy:** *Aloe magivera*

**Cost:** 400¥

**Street Index:** 2.5

**Legality:** Legal

**Availability:** 8/2 weeks

**Appearance:** Succulent cacti with a rosette of narrow, prickly-edged, fleshy leaves filled with bitter juice. Single leafless stalk growing just under 1 meter, terminating in an elongated cluster of down-pointing yellow to orange flowers.

**Climate:** Aztlan, CFS, The Ute, Pueblo Corporate Council

**Effects:** This plant can heal minor wounds [Moderate or less] when the juice is rubbed over or into it. This takes about 10 minutes for the magical effect to work, during which time, the wound tingles very powerfully [+1 to all Target Numbers for distraction]. It's powers are doubly effective against wounds caused by burns [Serious Wounds or less].

### Autumn Crocus

**Taxonomy:** *Colchicum autumnale*

**Cost:** 20¥

**Street Index:** 1.5

**Legality:** Legal

**Availability:** 6/6 weeks

**Appearance:** Herb which grows to 0.3 meters from an onion looking bulb. Large, lance-shaped leaves develop in spring. In the fall, a leafless flowering stalk yields a solitary white to pale purple crocus-like flower.

**Climate:** Damp meadows, fields, woodlands and mountains, especially in the Canadian parts of the UCAS and northern Sioux Nation.

**Effects:** Ingesting any part of this plant will cause a burning sensation in the throat, vomiting, and possible kidney and respiratory failure. [4D 1 hour after ingestion, Effects can last all day.]

**Balsam of Peru (Awakened)**

**Taxonomy:** *Myroxylon magibalsam*

**Cost:** 500¥/dose

**Street Index:** 2.5

**Legality:** Legal

**Availability:** 10/3 weeks

**Appearance:** Thick, fragrant resin (smells like cinnamon when fresh and vanilla when aged) extracted from a shade tree of up to 20+ meters tall. The evergreen tree leaves are oblong 8cm, sprinkled with transparent dots. White flowers terminate the branches.

**Climate:** Central America, southern Aztlan, northern South America

**Effects:** When applied to wounds, the balsam acts as a coagulant. It also contains magical properties which can heal tissue (heals 1-3 boxes). The resin is slightly astrally active, and is sometimes used to shellac doors or windows to make them astrally secure (one dose can cover a square meter).

>>>>[In order to get this stuff to work for astral security, you need to do a bit of enchanting. No magic required, but it needs to be mixed with distilled water and tannin just right, and I mean just right. Watching the whole process astrally can help a bit.]<<<<<

—Karla Nash (01:03:29/03-16-54)

**Barvine**

**Taxonomy:** *Hedera magihelix*

**Cost:** 500¥/meter2

**Street Index:** 3.0

**Legality:** Legal

**Availability:** 2/3 weeks

**Appearance:** Climbing plant with woody stem which get reach 35 meters or more. Dark, glossy, veined, evergreen alternate leaves are triangular and three-lobed.

**Climate:** Nearly anywhere

**Effects:** An Awakened form of common English Ivy, this plant is dual natured, and as such is used to cover buildings to make them astrally impenetrable.

>>>>[Too easy. Just go through the windows.]<<<<<

—Coma (22:24:58/01-26-54)

>>>>[Most buildings which use this are very secure, and so have no windows. Or, often the windows are very small, oddly proportioned or barred (with the ivy on the bars). If there isn't a space big enough for a person's real body, their astral form won't fit through either. And you can't move the ivy from the astral plane in anyway at all. Simple and effective. Your best bet is to wait until someone opens a door.]<<<<<

—Quarrel (18:25:57/11-30-54)

>>>>[Since this type of security is just as capable of keeping astral things in as out, some installations may have a back way in. It'll be very well hidden, but you might get lucky.]<<<<<

—Niche (05:44:57/12-17-54)

>>>>[Astral Security 101: Normal ivy is just as effective, chummers. All living things are impassable in astral space, remember? Using barvine is just plain dumb, since its dual-naturedness allows an astral magician to wack a spell through it into the physical plane...]<<<<<

—Gurth (21:05:40/05-01-55)



**Belladonna**

**Taxonomy:** *Atropa belladonna*

**Cost:** 1,200

**Street Index:** 1.0

**Legality:** Legal

**Availability:** 7/1 week

**Appearance:** Leafy, smooth branched stem growing to a meter with dull green alternate leaves of unequal size on the upper parts. Solitary bell-shaped purplish-brown flowers (June-July) arising from the leaf axils are followed by glossy black berries with inky purple juice (September).

**Climate:** Woods and wastlands. Eastern UCAS.

**Effects:** Belladonna contains atropine, scopolamine and hyoscyamine. Once ingested, Belladonna is a deadly poison [5D] which begins working in minutes.

**Black Nightshade**

**Taxonomy:** *Solanum americanum*

**Cost:** 70¥

**Street Index:** 2.0

**Legality:** Legal

**Availability:** 6/2 weeks

**Appearance:** .3 to 1 meter tall, with oval to lance-shaped leaves. White flowers with five backswept petals. Black berries

**Climate:** Sunny

**Effects:** All parts of this plant are poisonous when ingested (5D) and can kill within minutes.

**Name: Calabar Bean**

**Taxonomy:** *Physostigma venenosum*

**Cost:** 250¥

**Street Index:** 1.5

**Legality:** Legal

**Availability:** 6/4 weeks

**Appearance:** Vines rooting in riverbanks, climbing up to 20m into the trees. Large, purple flowers hand in the spring. After the flowers fall, 15cm pods develop, containing two or three flat maroon seeds

**Climate:** Calm rivers in dry climates, in the delta. Mainly found in the Niger Delta.

**Effects:** A drink made of the powdered beans contain physostigmine, which paralyzes the heart, causing death; often, however, the drink is rejected by the stomach before the drug can effect the body. [On a success of a Body(5) roll, the concoction is vomited, otherwise, the drink will kill the person in 10-30 minutes.]

>>>>[A lot of gangs in the Seattle area have taken to using this bean drink as an initiation technique. If the newcomer pukes, he's in, if not, he's buried.]<<<<<  
—Flash (10:01:32/04-29-54)

>>>>[Physostigmine can counteract the effects of atropine.]<<<<<  
—Doctorjack (02:32:44/08-18-54)

**Catnip (Awakened)**

**Taxonomy:** *Nepeta magicatoraria*

**Cost:** 100¥

**Street Index:** 1.5

**Legality:** Legal

**Availability:** 4/5 days

**Appearance:** Upright herb, 1 meter tall with branching square stems and toothed, heart-shaped opposite leaves covered with downy grey hairs.

Clusters of pale lavender tubular flowers (June-October) with purplish spots grow at the ends of the main stem. Minty smell  
**Climate:** Throughout North America

**Effects:** This plant secretes an oil which cats of all types find irresistible. It is as effective as its mundane cousin on mundane cats, but especially effective on paranormal felines, including Talis Cats, Sabre-Toothed Cats, and even Tiger Shapeshifters. It causes a very powerful euphoria in such creatures with few ill effects, and can reduce aggressiveness.



>>>>[When making friends with an angry Talis Cat, this plant can go a long way.]<<<<<  
—Coma (10:19:45/2-30-54)

**Chat**

**Taxonomy:** *Catha edulis*

**Cost:** 5¥/leaf

**Street Index:** 1.5

**Legality:** Legal

**Availability:** 4/3 hours

**Appearance:** Small leafy trees, very small white flowers.

**Climate:** Ethiopia

**Effects:** Chewing the three or four leaves of this tree for 10 minutes or so causes increased alertness, relief from hunger and fatigue, and mild euphoric high. [as stim patch(3), +1 Quickness]. Shredded leaves can be used to make a tea which has the same effect.

>>>>[This tea, when brewed with honey, is called Arabia tea and has some importance to Arab culture.]<<<<<  
—Fariba al-Hassan  
(01:59:30/2-17-54)

**Demonseed**

**Taxonomy:** *Buxus magisempervirens*

**Cost:** 500¥/fruit

**Street Index:** 2.0

**Legality:** Legal

**Availability:** 6/3 weeks

**Appearance:** Shrub from 1 to 2 meters high with small, juicy, elliptical leaves, dark green above and pale below. Clusters of small inconspicuous red flowers (April-June) produce small red, horned capsules containing seeds.

**Climate:** Only cultivated.

**Effects:** Crushing and drying the ripe fruit and seeds of this Awakened form of Boxwood, then inhaling the powder will bestow resistance to about all forms of spiritual activity [+2 to Target Numbers for spirit attacks and -2 to Power of any form of attack from a spirit]; however, this powder is slightly toxic [3S, immediate]. The effect lasts for 3-8 hours. It's main attraction for magicians is that any spirit summoned by a magician under the effects of this powder will be much less able to harm the magician should it go free [treat all attacks from the spirit on the summoning mage as if it were of a Force equal to one-half (round down) its actual Force]. As long as the magician was under the effects of the drug during the actual summoning of the spirit, this effect will last for the spirit's entire existence.

>>>>[When sum-moning big elementals or allies, this stuff can be a good move.]<<<<<

—Quarrel (19:48:15/4-28-54)

>>>>[You will never find this in the wild. This is because it is the results of a ritual involving it's mundane counterpart boxwood. It will only grow indoors.]<<<<<

—Arianna (18:13:15/8-6-54)

>>>>[I don't suppose you'd clue us into the ritual, would you?]<<<<<

—Coma (18:20:15/8-6-54)

>>>>[You suppose correctly.]<<<<<

—Arianna (18:21:20/8-6-54)

### Foxglove

**Taxonomy:** *Digitalis purpurea*

**Cost:** 200¥

**Street Index:** 2.0

**Legality:** Legal

**Availability:** 10/2 weeks

**Appearance:** A rosette of long-staled leaves with 1-2 meter stem growing out. Leaves are lance-shaped to oval. Spires of white to pinkish to red thimble-shaped flowers (June-September) are speckled with red dots.

**Climate:** Fields, moist clearings. Cascade Mountains

**Effects:** Chewing a leaf can cause paralysis and even death. [3D, plus, if any damage is taken,

reduce natural

Quickness by the number of boxes taken.

If quickness reduced below zero by one-half (round-down) its

original value or more, death results;

otherwise, one point returns each hour, allowing mobility when

Quickness reaches above zero.] This also has the odd effect of making Fox shapeshifters sneeze uncontrollably

[Willpower(5) each minute exposed to ignore effects).



### Godflesh

**Taxonomy:** *Stropharia cubensis*

**Cost:** 100¥ per mushroom

**Street Index:** 2.0

**Legality:** 5-M1

**Availability:** 7/3 weeks

**Appearance:** Small, wispy mushrooms with thin stems and narrow, white caps.

**Climate:** Yucatan

**Effects:** One of the strongest hallucinatory mushrooms, Godflesh was used ritually by Mayan in northeast Oaxaca. Eating this fungi caused severe hallucinations, which are very realistic. True reality is ignored. [Quickness -4, Charisma -1, Reaction -3, Intelligence -2(cognitive)/+4 perceptive, Willpower -1, Artistic Skills +2, tests requiring concentration at +2 Target Number.] Hilarity generally overtakes a user just before hallucinations begin.

### Healing Snakeroot

**Taxonomy:** *Sanicula magimarilandica*

**Cost:** 1,000¥

**Street Index:** 1.5

**Legality:** Legal

**Availability:** 6/1 week

**Appearance:** Thick, dark green, undulating, snake-like root. Leafless flower stalks over 1 meter. Leaves at base with long stalks, oval to elliptical, unequally toothed, often with deeply cut leaflets. Flower clusters in June and July with 23 jet black blossoms.



a 8S poison (this number includes the effects of the vulnerability to insecticides)].

>>>>[Yow. Talk about misinformation. We used some of this stuff loaded into NarcoJet rounds, and it worked great, with only one problem: bee spirits are completely unaffected by it. In fact, it seems to heal them and the scent of it attracts them, as well as normal bees.]<<<<<

—Coma (23:47:36/4-10-54)

**Kava**

**Taxonomy:** *Piper methysticum*

**Cost:** 30¥/leaf

**Street Index:** 3.0

**Legality:** Legal

**Availability:** 6/2 weeks

**Appearance:** Shrub with broad, heart-shaped leaves webbed with network of prominent veins.

**Climate:** South Pacific

**Effects:** Chewing on the leaves vigorously, soaking them in water or milk, then drinking the liquid produces a euphoric state, and when the user sleeps, the sleep is deep and dreamless. In large enough quantities (triple dose) can increase the force of heart action while decreasing pulse rate, induce a hypnotic state and paralyze large skeletal muscles, like those in the legs.

>>>>[I don't know why, but metahumans with allergies to sunlight really don't take this drug well. It can cause nausea and even coma. [5(level of allergy) stun damage.]<<<<<

—Misha (02:57:49/2-2-54)

**Mandrake (Awakened)**

**Taxonomy:** *Mandragora magiofficinarum*

**Cost:** 1,000¥

**Street Index:** 2.5

**Legality:** Legal

**Availability:** 12/5 weeks

**Appearance:** Vine-like member of the nightshade family with sparse, ovate leaves and whitish flowers. The root is turnip-like, contorted into a shape resembling a human being.

**Climate:** Mediterranean, also under hanged bodies.

**Effects:** Mandrake is credited with much more than it can actually do. Often in legend a catalyst for love magic, ritual sorcery and other sympathetic magic becomes much easier to cast on someone with whom the caster has shared mandrake [-2 to Target Numbers]. Mandrake is an aphrodisiac. Eating mandrake also makes connecting magically

to other minds easier [+1 die to Mind Probe, spells which control or alter conscious thought, and mana detection spells for 1d6 hours]. Continued use of mandrake can pose hazards to magical ability [make a Magic test against a target number of 2 plus the number of times mandrake has been used in the past 28 days to avoid losing a Magic point].



**Mirror Basil**

**Taxonomy:** *Ocimum magimasilicum*

**Cost:** 500¥

**Street Index:** 3.0

**Legality:** Legal

**Availability:** 8/2 weeks

**Appearance:** Bushy and up to a meter tall, with a square stem and many branches. Opposite, shiny green to purple, toothed leaves which are elliptical to oval and about 3cm long. Small white flowers grow in whorls of seven at the ends of the branches from June-September.

**Climate:** temperate North America, often hidden among common basil.

**Effects:** This Awakened form of common basil is thought to be the source of the legendary association of basil with the basilisk. Drinking a tea made of died mirror basil leaves will render the imbibor completely immune to the gaze of a basilisk for around an hour [(1d6+4) x 10 minutes].

>>>>[What they don't tell you is that anyone who uses this stuff will be targeted first by a basilisk's bite. I guess its some sort of smell or something (at least to them, I couldn't smell a thing) which really ticks them off. The plant itself doesn't seem to have this effect on them.]<<<<<

—Coma (06:39:17/07-3-54)

>>>>[This plant is often used in foci and fetishes for barrier and transformative magic.]<<<<<

—Ericka (14:17:59/11-10-54)

**Moneywort (Awakened)**

**Taxonomy:** *Lysimachia maginummularia*

**Cost:** 5,000¥

**Street Index:** 1.0

**Legality:** Legal

**Availability:** 12/5 weeks

**Appearance:** A creeping vine with trailing stems up to two meters long with glossy round leaves in opposite pairs. Golden yellow flowers (June-August) 2 to 3 cm across with five petals marked with dark spots.

**Climate:** Moist shores, roadsides, meadows and grasslands in southern UCAS, northern Atlantic coast and the Pacific coast.

**Effects:** The juice of this plant, boiled with wine and honey and ingested forms the most powerful magical heal-ing agent known [will heal six boxes of damage]. It begins working within minu-tes and takes 10 to 60 minutes to work, depending on the wound's severity; however, it makes the user very sleepy for hours after application. This plant must be harvested specially, and handling by mundanes spoils its effects. One plant provides up to four applications.

>>>>[On the streets, the syrup this plant makes is called beautiform, hiber, and le morte vim. It works wonders, but it tastes like shit.]<<<<<  
—Doctorjack (14:45:27/5-28-54)

**Opium Poppy**

**Taxonomy:** *Papaver somniferum*

**Cost:** 15¥

**Street Index:** 1.5

**Legality:** 5-M1

**Availability:** 4/3 weeks

**Appearance:** White, lavender, red or purple flowers with four large petals with dark centers

**Climate:** Most of Asia and the Mideast

**Effects:** This plant is the source of opium--the main ingredient the manufacture of morphine and heroin--as well as codine.

**Pareira**

**Taxonomy:** *Chondrodendron tomentosum*

**Cost:** 100¥

**Street Index:** 2.5

**Legality:** 8-M1

**Availability:** 10/2 weeks

**Appearance:** High climbing vine with woody stems and broad, veined leaves and bundles of what look much like hard, dark green grapes.

**Climate:** Peru, Ecuador, Colombia, Amazonia

**Effects:** From the stems of this plant is extracted a poison called curare. This is a very deadly poison, which relaxes the muscles of the body, even to the point of stopping the lungs from working. Curare can, in fairly small doses, paralyze a man in minutes (7D, 1d6 minutes onset time), leaving him immobile and asphyxiating until he dies.



>>>>[If this gets into your blood, you will be very, very sorry.]<<<<<  
—Blow (23:40:42/3-22-54)

>>>>[Not necessarily, if you've got the right wires. This toxin has been around for a long time, and many better blood filter cyberware systems were designed specifically to fight it. Seems like any system over level 3 works about 50% better against curare than against other blood-borne poisons. The same doesn't seem to hold for bio-ware.]<<<<<  
—Doctorjack (21:35:27/6-28-54)

**Peyote**

**Taxonomy:** *Lophophora williamsii*

**Cost:** 125¥

**Street Index:** 2.5

**Legality:** 3-M1

**Availability:** 9/2 weeks

**Appearance:** A tomato-sized round cacti, fleshy, greyish to chalky blue, with 5 to 13 ribs with pencil-like tufts of woolly white hairs instead of sharp spines. Massive carrot-like taproot. Tiny pinkish to creamy white flowers on top.

**Climate:** Aztlan desert, southern NAN deserts

**Effects:** Peyote contains over 56 alkaloid substances which act as drugs in humans, including mescaline (q.v.). When slices of peyote are chewed, the following effects happen within minutes: Quickness -1, Charisma -1, Reaction -1, Intelligence -1 (cognitive)/+3 perceptive,

Willpower -1, and hallucinations. When prepared properly and smoked, peyote can have a very profound effect: Quickness -3, Charisma -1, Reaction -1, Intelligence -2(cognitive)+4 perceptive, Willpower -1, possible uncontrolled astral perception [Essence(12), # successes \* 10 is what percent of the time you are astral], magical theory +4, Artistic Skills +2, tests requiring concentration at +2 T#, dream state trance, intense hallucinations. Addiction information and crash, permanent and addiction effects are as per mescaline. Duration of chewing peyote is 1d6 hours, smoking 3d6.

>>>>[The "proper" preparation mentioned is a magical ritual. You need an Awakened enchan-ter.]<<<<<  
—Poboy (07:49:59/01-05-54)

>>>>[It is very unlikely that this will make you walk astral space. Most people are unaware that many of the attributes sought by magicians from peyote are actually from an extremely rare awakened form of the plant. Here's a listing of it:

**Peyote (Awakened)**

**Taxonomy:** *Lophophora magiamsii*  
**Cost:** 12,500¥  
**Street Index:** 1.0  
**Legality:** 3-M1  
**Availability:** 14/5 weeks  
**Appearance:** As normal peyote, but always with 7 ribs. Not all 7-ribbed peyote plants are awakened.  
**Climate:** Aztlan desert, southern NAN deserts, very rare however  
**Effects:** This will almost always send mundanes into the astral [Essence(3), number of successes x 15 is what percent of the time you are astral], and might even get magicians to the metaplanes [Magic(9), number of successes is the quest rating]. Note that the latter can be fairly deadly if you are not ready for it. Other effects are: Quickness -3, Charisma -1, Reaction -1, Intelligence -3(cognitive)+4 perceptive/+7 to aura reading, astral perception, magical theory +5, Artistic Skills +3, dream state trance, intense hallucinations. This peyote is non-addictive and has none of the normal crash effects; however, you have little control of any astral body gained during the trip and may possibly stay in astral space too long. Also, magicians may experience a degradation in power for a time after coming down, especially if they went to the metaplanes.]<<<<<  
 —Quarrel (09:01:27/01-29-54)

>>>>[Well, whatever. I do know that peyote highs are nothing like mescaline highs. Peyote goes for all the senses, including smell and touch,

and is, well, kaleidoscopic. Right before you start hallucinating, this flashes of color across your vision. There is an old legend that says that El Santo Nio de Peyotl survives in the plants.]<<<<<

—Red Pawn (08:31:36/07-17-54)

>>>>[A peyote cult eventually turned into the Native American Church, which is still around. They had 250,000 members during the 1970's, but numbers are a bit sketchy now. They are dedicated to brotherly love, high moral principle, abstention from alcohol, and other niceties.]<<<<<

—Holly (01:18:59/11-2-54)



**Rauwolfia**

**Taxonomy:** *Rauwolfia serpentina*  
**Cost:** 100¥  
**Street Index:** 1.0  
**Legality:** Legal  
**Availability:** 4/1 week  
**Appearance:** 0.5 meter, graceful and woody. Oval leaves, dark green above and paler below, in whorls of three or four along the stem. Small pink to white flowers borne in terminal clusters produce tiny, oval, fleshy fruits which turn a shiny purple-black when ripe.  
**Climate:** Only grows in the wild. Mainly in Indonesia, India and Thailand.  
**Effects:** Chewing the root of this plant brings on a detachment while meditating [+1 to philosophic and artistic skills]. Over 50 chemicals can be extracted from this plant, including some to treat mental illness and high blood pressure. The fruits are rumored in folk lore to cure lunacy and lycanthropy. They also act as powerful tranquilizers [Tranq 6].  
 >>>>[Holy men in India, including Mahatma Gandhi, commonly used the root. ]<<<<<  
 —Wolf (21:54:29/06-25-54)

>>>>[I don't know about lycanthropy, but I've seen the fruits prevent shapeshifters from changing to their

animal forms, at least tempo-  
rarily.]<<<<<<  
—Quarrel (17:20:13/06-11-54)

### Sea Onion

**Taxonomy:** *Urginea maritima*

**Cost:** 10¥

**Street Index:** 1.0

**Legality:** Legal

**Availability:** 6/2 weeks

**Appearance:** A cabbage-sized onion, weighing up to 6 kilos. Leafless, purple flower stalk with a long cluster of whitish or rose covered flowers. The onion is either white or red.

**Climate:** The white variety is found in sandy coastal areas fringing the Mediterranean, the Canary Islands, and South Africa. The red is found mostly Algeria and Cyprus.

**Effects:** Both varieties of onion are loaded with chemicals, mostly those which stimulate heart activity. The red variety contains a highly poisonous substance called scilliroside. When ingested, it would be lethal, but the human body vomits it out immediately before it takes effect. It is a lethal rat poison, however, as rats and other rodents are not able to vomit. The red version is much harder to find, as it is not harvested for its other drugs [x5 cost].

>>>>[Devil Rats will eat the red Sea Onion like candy, until it kills them. One weird thing, though, is that the outer layers of the onion and the layers close to the heart have no chemicals in them at all. Only the layers in-between are useful.]<<<<<<  
—Misha (14:20:31/06-01-54)

### Sinicuichi

**Taxonomy:** *Heimia salicifolia*

**Cost:** 250¥/dose

**Street Index:** 2.5

**Legality:** Legal

**Availability:** 9/4 weeks

**Appearance:** Small, sparsely leafed shrub, with twined green leaves up the stems and 6-petaled, white flowers at mid-stem.

**Climate:** Central America

**Effects:** Picking the leaves from the sinicuichi and letting them wilt, then crushing them in water and fermenting the mixture in the sun will produce a drink with very unique properties when ingested. Most distinctive among these are vivid remembrances of the past (as far as childhood, or even pre-natal memories) and solely auditory

hallucinations. These effects are accompanied by a giddy, drowsy euphoria, a darkening of vision, a shrinking of the surrounding world, and altered time/space perception. A single plant can prepare from three to eight doses.



### Smooth Strophanthus

**Taxonomy:** *Strophanthus gratus*

**Cost:** 400¥

**Street Index:** 5.0

**Legality:** 3P-M1

**Availability:** 10/4 weeks

**Appearance:** Woody, climbing vine, up to 10 meters or more. Uses branches like arms to climb trees rather than tendrils. Glossy evergreen leaves, thick and leathery. Terminal clusters of beautiful, bell-shaped, purple and white flowers resembling begonias, but which smell like roses at night.

**Climate:** Deciduous forests in tropical West Africa

**Effects:** The flowers are used for ornamentation. The plant is the source of the compound ouabain, a powerful, immediate heart stimulator. When this chemical is injected in small quantities, it can save humans from recent heart damage. In larger doses, it is very lethal [7D, immediately].

>>>>[This was used as arrow poison by tribes in Africa long before Dr. David Living-stone brought it to European attention.]<<<<<<  
—Doctorjack (01:07:57/04-13-54)



### Fly agaris (Awakened)

**Taxonomy:** *Amanita magimuscaria*

**Cost:** 1200¥/mushroom

**Street Index:** 4.5

**Legality:** 5-M1

**Availability:** 10/3 weeks

**Appearance:** Think musroom with white, thick base and crimson head, with white splotches. Starts as an egg-sized, fluffy ball which appears as if wrapped in white wool. As it grows, it bursts, revealing the red skin.

**Climate:** Siberia, northern India

**Effects:** This mushroom, when properly filtered, provides a user with an intoxication, much like alcohol with an added side effect: an empathy for

those around him, especially if those around him are also using the drug. [+2 Charisma, -2 bonus to Charisma, Etiquette and Negotiation target numbers, for 1d6/2 hours; double this effect towards those also on the drug. Also Quickness -2, Intelligence -2, Willpower -1.] This has earned this mushroom the name "brotherhood" on the streets. The proper method of filtration is to pound out the juice, and filter the juice through a wool cloth, then mix it with water, milk, honey or barley water and drink.

>>>>[This mush-room is the plant which was known as Soma to a group in northwest India circa 1600 B.C. called the Aryans. It is the only plant in the world to have been deified; almost 160 books of hymns were written about Soma. Soma seemed to have vanished from the earth for nearly three millennia, and it was not until 1970 that R. Gordon Wasson connected Soma to the fly agaris. He had to wait until the Awakening for Soma to reach its full effect, though, as it works magic-ally.]<<<<<

—Arya ben-Yosef  
(19:23:25/04-5-54)

>>>>[So that's where Huxley got the nameI.]<<<<<

—Ivy Tower (10:18:38/05-6-54)

>>>>[A more arcane filtration (in both senses of the word) is to let rain water soak into the mushroom, then perform an enchantment, and eating the mushroom. If done correctly under moonlight, the resulting effect allows a better communal with spirits [1 extra service from a summoning].]<<<<<

—Quarrel (01:37:29/05-26-54)

>>>>[There's yet another filtration, chummers, and it's hanious. First, get some people to consume the stuff made by the first kind of filtration. Then, drink their urine. It's gross, but it works wonders. It works for about five "generations" unless one of those is a magician. I did it, chummers, and I'm here ta tell ya, I thought I was talking to God. [Any astral quest undertaken while under this filtration is performed as if it were 2 Rating points lower for the purposes of target numbers and numbers of dice used. Also, any conjuring test is at a -1 T# bonus.]]<<<<<

—Inga (21:27:57/11-10-54)

**St. Michael**

**Taxonomy:** *Angelica magiarchangelica*

**Cost:** 500¥

**Street Index:** 2.0

**Legality:** Legal

**Availability:** 6/4 weeks

**Appearance:** Herb with thick, hollow stems up to 2 meters. Pinnately compound leaves, with toothed leaflets and enlarged sheaths at the base of the leaf stalk.

**Climate:** Temperate steppe in high latitude UCAS

**Effects:** Chewing the root of this Awakened form of angelica can boost the immune system [+1 to resist diseases for 1d6 hours] and has very odd effects on the

astral aura for a few hours. Most of these effects are not noticeable, but it does make the user slightly immune to many of the powers which nature spirits can use. [+3 dice to throw off effects, such as alienation, et. al.] This root also increases appetite for its duration [x2].

>>>>[This aura fluctuation is not significant, but can confuse low force watchers sent to find you.]<<<<<

—Quarrel (09:21:19/08-25-54)



**Strychnine Tree**

**Taxonomy:** *Strychnos nux-vomica*

**Cost:** 50¥/berry

**Street Index:** 2.5

**Legality:** 6-M1

**Availability:** 10/2 weeks

**Appearance:** Medium-sized deciduous evergreen, with a thick, crooked trunk. 9cm oval leaves are borne in pairs and deeply veined. Small, loose clusters of greenish flowers at the branch ends, followed by fleshy, orange-red berries 4cm wide.

**Climate:** Tropics and subtropics in southeastern Asia and Australia.

**Effects:** The berries are bitter and very lethal when consumed. Victims of strychnine poisoning suffer violent seizures, sometimes nearly bent in half, without losing consciousness. The face is often distorted into a hideous mask. Death by strychnine can take up to an hour [6D. Make test every ten minutes, subtracting 1 from the power until the power reaches zero or the victim is dead.]

**Tess' Bloom**

**Taxonomy:** *Orchidaceae magisupplus*

**Cost:** 10¥

**Street Index:** 1.0

**Legality:** Legal

**Availability:** 3/3 days

**Appearance:** A medium sized member of the orchid family, with white petals with black and green flecks toward the center of the flower.

**Climate:** Tropics, Hawaii

**Effects:** Discovered two years ago by a free spirit called Dion Kimber, this Awakened orchid has rapidly infused the magical community, especially magical security companies, and is grown greenhouses everywhere. Although rather commonplace for an orchid, it possesses a pleasing, brilliant astral aura. It is mainly harvested for its ability to raise the background count in areas in which it prospers. The extraneous astral patterns created by a room full of these plants has been called extremely beautiful, and compared in intensity to that within major cathedrals [Background Count = 4].

**Torus Buckthorne**

**Taxonomy:** *Rhamnus magifrangula*

**Cost:** 1,000¥/berry

**Street Index:** 5.0

**Legality:** Legal

**Availability:** 10/4 weeks

**Appearance:** Deciduous shrub, up to 4 meters tall. Glossy oval green leaves, 2-7cm long. Green to grey bark. Small greenish white flowers grow in small clusters at the leaf joints from May to June. Most distinctive are the pea-sized berries which are torus (doughnut) shaped, the only berries ever found that exhibit such a shape. The berries turn from green to red to black.

**Climate:** Eurasia, North Africa, northeast UCAS, Quebec

**Effects:** This plant is the Awakened form of Alder Buckthorn. Eating the berries will, within minutes, make the user more resistant to magical forces. [One berry will give an extra die of magical defense to mundanes and magicians alike, but only for themselves, it cannot be extended to another. Eating berries is cumulative, but only to a number of extra dice equal to one-half Essence (round up). The magic resistance will last for 1d6 hours.]

>>>>[Only the red berries will help. You can tell if the berries will work by looking astrally into the empty center. If the berry is effective, the

hole will be filled with astral energy.]<<<<<<  
—Quarrel  
(02:35:18/05-12-54)

**Vambane**

**Taxonomy:** *Allium magisativum*

**Cost:** 300¥/bulb

**Street Index:** 1.0

**Legality:** Legal

**Availability:** 5/2 weeks

**Appearance:** With its white bulb, composed of small cloves, and pungent odor, this plant is completely indistinguishable from garlic.

**Climate:** Pastures, open woods. Eastern North America

**Effects:** This Awakened form of garlic provide the basis for the legend that garlic would repel vampires. Vambane reacts strongly with humans and metahumans infected with HMHVV, irritating mucous membranes and irritating skin. Even the odor can cause such effects, although to a much more minor extent.

>>>>[I don't think this always works. I've only seen it twice, once it worked, once it didn't.]<<<<<<  
—Torment (14:45:27/05-28-54)

>>>>[Could be that it isn't always effective, but I think it more likely that you got slotted by your Talismonger. There is absolutely no way you can tell vambane from normal garlic. None. Not even astrally.<<<  
—Misha (07:05:20/07-16-54)

>>>>[Hmm. My experience was that the reason this stuff works is that it is a powerful psychological deterrent. Nothing happens immediately after exposure, but after about a day, an HMHVV carrier's lungs start burning, itching skin, watering eyes, etc. None of this is damaging, but can very very distracting because nothing helps the irritation and it lasts for months. So, the next time the vamp smells the stuff, he runs like hell, if he's smart.]<<<<<<  
—Vanth (06:03:45/08-01-54)

**Underdog**

**Taxonomy:** *Apocynum magicannabinum*



**Cost:** 500¥

**Street Index:** 3.0

**Legality:** Legal

**Availability:** 3/5 weeks

**Appearance:** Branch-ing stems, 1-2 meters tall, with oval to lance-shaped leaves in opposite pair. Incon-spicuous green-white flowers and 18cm slender pods, contain-ing silky, tufted seeds. All parts of the plant produce a bitter, milky sap.

**Climate:** Thickets and fields in Temperate UCAS, often around hemp dogbane plants.

**Effects:** An Awakened form of hemp dogbane, the sap of this plant, when mixed with alcohol, forms a poison lethal to paranormal dog-forms, like the barghest and hellhound [8D, Instant]. A single plant can yield up to 10 doses of this drug.

## FAUNA

A few animals are worth mentioning. You're on your own in terms of how you get these damn things. Numbers here are nearly meaningless, but can give a rough idea. Conditions and location will alter the price, legality, street cost, and availability of these animals.

### Cyrano

**Taxonomy:** *Nasus magitrilleanus*

**Cost:** 1,500¥

**Street Index:** 3.0

**Legality:** 6-M1

**Availability:** 14/3 weeks

**Appearance:** A very small (3mm thick, 1 cm long) invertebrate earthworm-looking parasite. Skin color changes monthly, but is always consistent, usually bright pastel colors.

**Climate:** Jungle

**Effects:** These small parasites are becoming very popular in big cities. When placed in one nostril, these worms slither up the sinuses and hook into the hosts bloodstream. After brief but severe pain, the cyrano drinks the blood of the host, replacing it with a fluid from its own body. This fluid provides a constant, dulling euphoria in its host [-2 Intelligence, -1 Willpower, -4 Reaction, as Level 1 damage compensator]. This effect lasts until the parasite is removed. Even after very short exposure, the parasite's fluid is very addictive [Addiction: 8p after removal (+1 for every two months of life with the parasite)]. An addict is fine as long as a parasite lives within him. Without it, he will die within weeks [-1 Willpower per week, resist with Body(8)].

>>>>[Jesus. Is that a worm in your nose, or are you just glad to see me?]<<<<<

—Punisher  
(08:13:27/02-09-54)

>>>>[This worm alters the users aura, pretty significantly. It is easy to spot if someone using one of these things, but even if you are familiar with the persons aura from before, it becomes unrecognizable, though it is obvious that the person is under the influence of the worm.]<<<<<

—Quarrel (15:01:30/05-19-54)

>>>>[Each time the worm changes color, it causes about an hour of extreme pain. Once done, the user's aura (as well as the worm's) has mutated. This can be useful if people have a habit of tracking you by aura, but it is rarely worth it.]<<<<<

—El Majid (14:11:46/10-17-54)



### Gin toad

**Taxonomy:** *Bufo mexi-calus*

**Cost:** 500¥

**Street Index:** 1.5

**Legality:** Legal

**Availability:** 8/1 week

**Appearance:** A small brownish green toad, with very slick skin short jumping legs.

**Climate:** Central America

**Effects:** The oil on the skin of this toad is a hallucinogen, especially when mixed with alcohol. Seattle clubs are beginning to serve this in back rooms. You get a martini and a toad in a cage, you let the toad swim for a while, take it out and drink. This often kills the toad, but not always. The hallucinations are solely visual, and are not very powerful. [-1 Quickness, -2 perception, for 1d6/3 hours.]

### Marine toad

**Taxonomy:** *Bufo marinus*

**Cost:** 1500¥

**Street Index:** 2.5

**Legality:** Legal

**Availability:** 8/1 week

**Appearance:** These are large brownish toads with slightly oily, slick skin, and a pale bump (a poison gland) behind each eye.

**Climate:** Central America

**Effects:** The oil of the skin of these animals is a poisonous hallucinogen. Pinching the poisons glands can cause a powerful neurotoxin to shoot out. When this toxin makes contact with mucous membranes, death usually results [at the end of the combat turn, 6D]. Licking the toad's skin, in moderation, is mostly safe, and yields a hallucinatory experience on par with LSD.



**RADTECH INC. CP2020 EQUIPMENT  
 CATALOG**  
**"Radical Equipment for the  
 Urban Thrasher"**

**RADTECH POWERED  
 'ASSAULT-COURIER'  
 SERIES**



>>>>[I found this file somewhere (can't remember where :), containing skateboards and associated gear for CP2020. So, I thought, nice for SR. Let's convert it. The thing was written (for CP2020) by Storm Widow, and yours truly converted the stats to SR11, and also (again) edited the text. I added the Skate skill, and chucked out all the Imperial measurements as well.]<<<<<  
 —Gurth (F1:F2:F3/F4-F5-F6)

**Skate skill**

First off, introducing Skate skill. This is a Concentration of Athletics and governs the use of all sorts of skating devices: ice skates, skateboards, roller-skates, and similar items.

Skating counts as movement, and is either walking or running. When "walking," a number of meters equal to the skater's Quickness, multiplied by 1.5, can be moved in a Combat Phase. When "running," the maximum distance is Quickness x 1.5 x Movement Multiplier. Whenever a skater moves across difficult ground, a skill test is required, using a Target Number based on the difficulty of the terrain. If the test fails, the skater falls and takes (1D6)L damage. The Rule of Six *does* apply to the 1D6 rolled to determine Power Level. If the test has 1 success, the skater does not fall, but may not move any further in the current Combat Phase. If the test generates 2 or more successes, the skater may continue his or her movement.

Skaters may increase their movement rate by making a Skate skill test against a Target Number 4. Each success increases the character's effective Quickness by 1 for that Combat Phase (this is the same as normal running, page 83, **SR11**, but may also be used when "walking").

A skater is more prone to being knocked over when hit by an attack: add +2 to the Target Number to remain standing.

**Rechargeable Battery Pack**

Housed in a Ballistic Nylon casing (10 x 4 x 1.5 cm), RadTech Battery Packs come with lifetime warranty. A flip-out power adapter located on the battery's side plug directly into a 110V socket. A complete recharge takes 12 hours, quick-charging in 8 hours (75% power).

Conceal	Rating	Weight	Availability	Cost	Street Index
11	—	.1	2/36hrs	50¥	.8

## RadTech Patented SmartWheel and Surface Imaging Sonar/SmartLogic Electronics



Each SmartWheel contains 24 piston-spokes around and 5 deep, attached to ArachnoFiber contact pads. Combined with an advanced surface imaging short range sonar, the SmartLogic chipset anticipates terrain layout, extending and retracting individual pistons to compensate for ground obstacles (-2 to Target Numbers of Skate skill). SmartWheel equipped, skating speeds can be increased by over 40% (+1 Quickness for movement purposes only, when skating only)! Excessive stress on a contact pad will cause the spoke to retract for a millisecond, making controlled sideways skids and/or stopping possible.

**Smartwheel:\***

Conceal	Rating	Weight	Availability	Cost	Street Index
—	+1	—	6/36hrs	90¥	1.2

**SmartLogic:\*\***

Conceal	Rating	Weight	Availability	Cost	Street Index
—	-2	.1	6/36hrs	210¥	1.2

\* = per wheel

\*\* = for a SmartLogic unit controlling four wheels

## Sonic-II SkateBoard

Mounted beneath an AlloyFiber plank, two rechargeable battery packs power a set of SmartWheels and SmartLogic electronics for 12 consecutive hours. A Sonic-II skater can reach speeds in excess of 50kph (effectively giving the user a Quickness of 12, for movement only)! Vehicle assisted, Sonic-II's will handle surfing speeds up to 80kph (effective Quickness 20; requires a Skate skill test with Target Number 10), although maneuvering at this velocity is not recommended (requires another skill test)

A smoke projector, installed under the Sonic-II's deck, is available for an additional 250¥. Smokescreens impose the normal Target Number penalty for shooting through them (vehicle sensors and ultra-sound sights are not affected). Thermographs are immune, unless IR smoke is employed. Reload canisters (5 x 9 x 2 cm) cost 10¥ (IR smoke is 250¥) and last for 1 minute. To activate the smokescreen, a skater must reach under the board's side and depress the release mechanism.

Conceal	Rating	Weight	Availability	Cost	Street Index
2	—	2	8/48hrs	750¥	2

## Spider-IX SkateBoot

Featuring a standard roller-skate configuration (2-by-2) for stability and maneuvering speed, the Spider-IX comes equipped with our patented retractable SmartWheels. Touch sensitive side panels enable the SmartWheels and assembly to collapse, partially folding within the boot's sole. When retracted, the Spider-IX leaves a distinctive double-V depression. A durable PolyCarbonite shell protects the wearer and SkateBoot electronics in any urban situation. Twin battery packs, fitted behind the ankles, provide 12 hours of constant use. Outfitted with Spider-IX's, a skater can reach speeds of over 60kph (effective Quickness 15)! Vehicle assisted, SkateBoots will handle surfing speeds up to 90kph (effective Quickness 25; requires a Skate skill test with Target Number 10), although maneuvering at this velocity is not recommended.

**Per pair:**

Conceal	Rating	Weight	Availability	Cost	Street Index
2	—	2	9/60hrs	1,900¥	2.1

## RadTech Patented MagnaPoon

Constructed of light Orbital CrystoSteel, the MagnaPoon weighs just 0.4kg! An ElectroMagnetic ring (2mm thick) with ArachnoFiber padding around, is mounted at the front, quickly tapering to a cable attachment. Retracted, the MagnaPoon folds within a 2cm muzzle, fanning out to a 6cm diameter when fired. A high efficiency microturbine, located in the poon head's center, is powered via the cable's conductive core. Three exhaust ports, on the MagnaPoon's back-side, provide 60m/sec propulsion (6L damage). 16 CarboSteel blades, between the turbine and magnetic ring, assure straight flight. The MagnaPoon will stick to any steel, iron, or nickel (slightly) based metals.



## StreetMaster PoonGun

The StreetMaster is equipped with a triangular molded hand-grip, and launch control unit extruding from it's right side. A Tight-Beam Laser sight (red dot) mounted on the top is used for aiming. Usually held in the left hand, the right operates the control unit. When fired, the MagnaPoon is followed by a 15m, 4mm thick CarboNylon weave cord. Cord retraction speeds are selectable up to 30m/sec. An adjustable resistance reel buffers sudden changes in cord tension, minimizing the risk of shoulder injuries. A single power-pak in the hand-grip provides 6 hrs of continuous use.

Type	Conceal	Ammo	Mode	Damage	Weight	Availability	Cost	Street Index
Taser*	3	1 (m)	SS	6L	3.5	8/72hrs	980¥	2.2

\* = use Taser ranges, but add +1 to all Target Numbers.

## Highway-Hawk Mark-II PoonGlove

Built from hard PolyCarbonite, the Highway-Hawk features a surface mounted MagnaPoon with a 25m, 5mm thick retractable CarboNylon weave cord. Retraction speeds are selectable up to 40m/sec. An adjustable resistance reel buffers sudden changes in cord tension, minimizing the risk of shoulder injuries. Targeting is performed via the top-mounted, Tight-Beam Laser sight (red dot). Twin rechargeable power packs (10 x 4 x 1.5 cm) provide 10 hours of continuous use. All PoonGlove functions are controlled by a touch-sensitive keypad, located at the wrist area. For an extra 2,550¥, the Highway-Hawk can be outfitted for SmartGun control. Available in flat-black, ash-gray, china-red, and fluorescent-yellow.

Type	Conceal	Ammo	Mode	Damage	Weight	Availability	Cost	Street Index
Light*	7	1 (m)	SS	6L**	1	10/5 days	1,680¥	3.75

\* = use Light Pistol ranges, but add +1 to all Target Numbers. Maximum range is 25 meters.

\*\* = when a hand wearing this glove is used to punch, it does (str+1)M Stun damage.

==== | ( ) | = : | ' | | / \ | | | ( ) | / \ | a.k.a. J.S. Morisset  
 ... There's a Mr. Death at the door; he's come about the reaping.

>>>>[Hey! How did you...]<<<<<  
 —Gurth (F7:F8:F9/F10-F11-F12)

**Y**ou need every edge you can get.

On the streets of the Sprawl, you don't get a second chance if your opponent has the better equipment. Get yourself the latest gear, and know what they will be using against you.

**RUNNING GEAR** is a compilation of articles, both from the Internet and newly-written, to provide **Shadowrun** players with new and varied equipment. It covers topics such as weapons, explosives, drugs, and other vital needs for the serious shadowrunner.

**RUNNING GEAR** is an unofficial sourcebook for  
**SHADOWRUN, SECOND EDITION.**

Shadowrun® is a Registered Trademark of FASA Corporation.  
Produced in the Netherlands.

123456789000
1234
123456789000
1234
Barcodes? We don't need no stinking barcodes!
<b>\$00.00</b>